

A CASE FOR CALCULUS

BY JAMES D. NICKEL

PRÉCIS

1. HISTORICAL BACKGROUND	2
2. CATCH A FALLING STAR	8
3. EXPLORING THE DERIVATIVE.....	17
4. MORE ON MOTION	28
5. REVERSING THE PROCESS.....	33
6. PUTTING THE INTEGRAL TO WORK.....	42
7. SYNOPSIS	50

Note: This essay is extracted from a set of
Lessons from the forthcoming textbook
Mathematics: Building on Foundations.

A CASE FOR CALCULUS

BY JAMES D. NICKEL

1. HISTORICAL BACKGROUND

Many high school students do not realize that the courses they take, algebra, geometry, and trigonometry, *are leading somewhere*. To graduate from high school, without knowing something about the *telos* or the ultimate goal of elementary mathematics is, to me, an educational crime. A truly liberal arts program should include, in the realm of mathematics, some elementary teaching, if not a full year course, in what is called the calculus. In order to be ready for the calculus, a mastery of the following topics is required:

1. Arithmetical operations (addition, subtraction, multiplication, and division).
2. Exponentiation.
3. Prime numbers and composite numbers.
4. The Fundamental Theorem of Arithmetic.
5. Perimeter, area, and volume.
6. Functions and graphs.
7. Arithmetic series.
8. Combinations and permutations.
9. Geometric congruence and similarity.
10. Pascal's triangle.
11. The binomial theorem.
12. Algebra and the solution of equations.
13. Right angle triangles.
14. The Pythagorean Theorem.
15. The extraction of roots
16. Quadratic equations and equations of higher degrees.
17. Vectors.
18. The arithmetic mean, mode, and median.
19. Geometric and harmonic series.
20. The limit concept (convergence).
21. Divergence.
22. Irrational numbers.
23. Real numbers and the power of the continuum.
24. Logarithms (common and natural).
25. Fractional exponents.
26. e .
27. Simple and compound interest.
28. "Thou shalt not divide by 0."
29. Linear functions, slope, and distance formula.
30. Conic sections.
31. Circular or trigonometric functions.
32. Radians.
33. Power series.
34. Triangulation.
35. Polar coordinates.
36. Logarithmic or equiangular spiral.
37. i .
38. Complex numbers.
39. Complex number plane.

Copyright © 2007

www.biblicalchristianworldview.net

A CASE FOR CALCULUS

BY JAMES D. NICKEL

40. Fundamental Theorem of Algebra.

“Thou shalt not divide by 0” and the limit concept will form the basis for this essay, a brief and rudimentary introduction to the methods of the calculus.¹ The historical roots of the calculus can be traced back to the paradoxes of Zeno (5th century BC) in which he concluded that motion was impossible. The *convergence of an infinite series to a limiting value*, a foundational concept of the calculus, resolved Zeno’s conundrum. Archimedes (3rd century BC) anticipated another method of the calculus when he calculated the lower and upper limits of π , called the *method of exhaustion*.

The calculus really came into its own in 17th century Europe (England and Germany). Before we investigate the history behind this fruitful development, let’s briefly review the motivations for the development of the branches of mathematics that provide the foundation for the methods of the calculus, namely algebra, geometry, and trigonometry.

The principles of elementary algebra provided solutions to simple physical problems that in their mathematical form called for solving first, second, and higher degree equations with one or two unknowns. The plane and solid geometry of Euclid tackled problems dealing with the calculation of perimeters, areas, and volumes of common figures. Plane geometry also defined the conditions under which two figures, for example, two triangles, are congruent or similar. Trigonometry, along with the invention of the sextant and transit, enabled one to determine immeasurable distances, either across a river or across the heavens. The coordinate or analytic geometry of René Descartes (1596-1650) and Pierre de Fermat (1601-1665) greatly simplified the study of important curves such as the paths of projectiles, planets, and light rays.

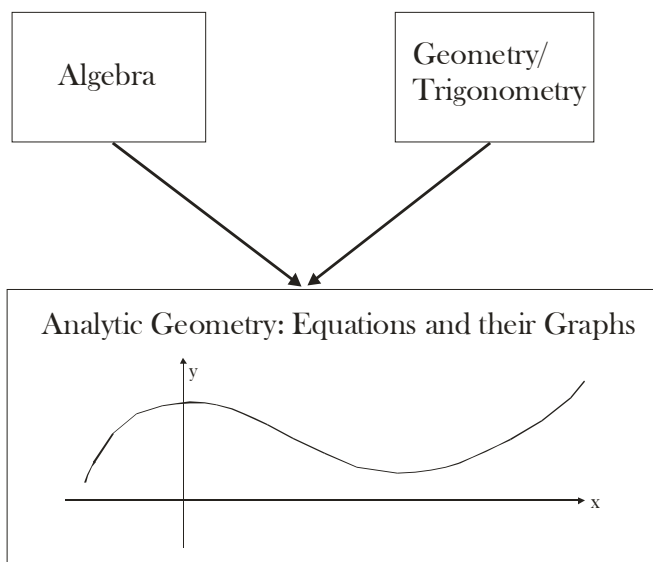

Although the ancient Greeks anticipated the calculus, they could not advance the subject to its fullest for two reasons. First, they had trouble with one concept, namely *infinity*. When Archimedes *exhausted* the circumference of the circle with inscribed and circumscribed regular polygons, he calculated his solution in terms of *finite* sums. The word *infinity* never appeared in any of his arguments. In the case of Zeno, he concluded that motion was impossible because he could not accept the fact that an *infinite* sum of numbers could converge to a limit. The *transcendent* nature of infinity rattled the Greek mind. By transcendent, I mean that the concept of infinity goes beyond the limits of human reason and for that reason the Greeks were horrified by it (in Latin, *horror infiniti*). The Greek worldview erred in one of two ways; either they absolutized number (in the case of Pythagoras) or they absolutized reason (in the case of their philosophers). When a culture absolutizes (or deifies) any aspect of God’s creation, *then nothing can transcend deity*. Since the concept of infinity transcended Greek deity (i.e., human reason), then the Greeks, shrinking before its silence, swept this intruder under the proverbial rug.

¹ Many university calculus textbooks run over 1,000 pages. Needless to say, this essay will be a basic introduction. I will be teaching you the rudiments of how to “drive” by taking you to some backcountry roads for some foundational lessons. University calculus is like driving on a freeway during rush hour traffic. It is best that you have some elementary driver training and know the basics before you take to the road in that context!

A CASE FOR CALCULUS

BY JAMES D. NICKEL

Second, since the Greeks tied form to number in the context of plane and solid geometry, their understanding of algebra was inadequate. Because they were tied to rhetorical algebra, they did not develop a collection of symbols and a set of rules with which to operate upon these symbols. The reason why they failed to embrace a truly symbolic algebra is again worldview related. Their *static* view of the world is reflected by their geometric commitments. In plane geometry, all lengths have fixed (or static) magnitudes. In symbolic algebra (fully developed in Western Europe), letting x be equal to a variable quantity presupposes a *dynamic* view of the world. That is, the *domain* that x can assume can *range* across the continuum. Greek geometry, with its static line segments and angles (which serves its intended purpose quite well), is alien to the dynamics of the continuum. Greek geometry cannot express relations among *variable* quantities.

Nearly two millennia after Archimedes, the founder of symbolic algebra François Viète (1540-1603), in a work on trigonometry (published in 1593), discovered a remarkable formula involving π :

$$\frac{2}{\pi} = \frac{\sqrt{2}}{2} \cdot \frac{\sqrt{2+\sqrt{2}}}{2} \cdot \frac{\sqrt{2+\sqrt{2+\sqrt{2}}}}{2} \dots$$

Note the ellipsis ...

indicating that $\frac{2}{\pi}$ is an *infinite* product. As far as mathematics historians can ascertain, this was the *first* time an infinite process was explicitly written as a mathematical formula. Viète's use of the ellipsis signaled an acceptance by the mathematical world of the infinite process and opened this method to widespread



François Viète (Public Domain)

use.

Viète, from France, can cite Nicole Oresme (ca. 1323-1382), not only as a fellow countryman, but as one of his mathematical ancestors. Oresme anticipated the coordinate geometry of Descartes and his analysis of the divergence of the harmonic series was profound. Oresme also pioneered mathematical methods that dealt quantitatively with change and rate of change. His work in this area foreshadowed many of the methods of the calculus. He, like many medieval

Infinite series formulas involving π :

$$\frac{\pi}{4} = 1 - \frac{1}{3} + \frac{1}{5} - \frac{1}{7} + \frac{1}{9} - \frac{1}{11} + \frac{1}{13} + \dots \text{(Gregory, 1671)}$$

$$\frac{\pi^2}{6} = 1 + \frac{1}{1^2} + \frac{1}{2^2} + \frac{1}{3^2} + \frac{1}{4^2} + \dots \text{(Euler, 1736)}$$

$$\pi = 16 \left(\frac{1}{5} - \frac{1}{3 \times 5^3} + \frac{1}{5 \times 5^5} - \frac{1}{7 \times 5^7} + \frac{1}{9 \times 5^9} - \dots \right)$$

$$-4 \left(\frac{1}{239} - \frac{1}{3 \times 239^3} + \frac{1}{5 \times 239^5} - \dots \right) \text{(Machin, 1706)}$$

$$\pi = 2\sqrt{3} \left(1 - \frac{1}{3 \times 3} + \frac{1}{5 \times 3^2} - \frac{1}{7 \times 3^3} + \dots \right) \text{(Sharp, 1717)}$$

Some of these formulas were developed in the Hindu/Arabic cultures, but failed to make their way to the West. European mathematicians "re-discovered" them on their trek to the development of the calculus.

The relationship between π , the ratio of the circumference to the diameter of a circle, and these series is a constant source of wonder because these formulas are as remote from geometry as anything imaginable. Yet, the connection exists ... another wonderful commentary on the unity and diversity found in the structure of mathematics.

A CASE FOR CALCULUS

BY JAMES D. NICKEL

theologians, did not shy away from using the concept of infinity in mathematical processes. Why? Since infinity (without bounds) was an attribute of the Biblical God, medieval theologians (also called scholastics²), contra Greek philosophers, were not afraid of it.

Concerning the meditations of the scholastic philosophers, mathematics historian Howard Eves observes:

... [they] led to subtle theorizing on motion, infinity, and the continuum, all of which are fundamental concepts in modern mathematics. The centuries of scholastic disputes and quibblings may, to some extent, account for the remarkable transformation from ancient to modern mathematical thinking.³

The medieval theorizing on motion reflected a change in worldview: from the static view of the Greeks to a dynamic view (that led to the development of symbolic algebra). In this context, science historian Stanley L. Jaki adds to the list of ideas embraced by medieval theologians:

Inertia, momentum, conservation of matter and motion, the indestructibility of work and energy – conceptions which completely dominate modern physics – all arose under the influence of theological ideas.⁴

Mathematics historian Carl Boyer (1906-1976) remarks that, in this theorizing, “there was perhaps as much originality in medieval times as there is now.”⁵ The application of the concept of infinity to the study of change in motion is foundational to the calculus. Boyer comments about the impact of the input of the scholastics in this area:

The blending of theological, philosophical, mathematical, and scientific considerations which has so far been evident in Scholastic thought is seen to even better advantage in a study of what was perhaps the most significant contribution of the fourteenth century to the development of mathematical physics ... a theoretical advance was made which was destined to be remarkably fruitful in both science and mathematics, and to lead in the end to the concept of the derivative.⁶

Before we continue, please note two things. First, we will encounter and define the concept of the derivative shortly. Second, given modernity’s abhorrence of anything that smacks of the supernatural and its arrogant premise that those who believe in Scripture believe in fairy tales, how then, could the theology of Scripture (a fairy tale at best) be the source of such remarkable fruit in science and mathematics? The answer of modernity is an answer of silence.

In his autobiography, historian Arnold Toynbee (1889-1975) notes the significance of the calculus:

Looking back, I feel sure that I ought not to have been offered the choice [whether to study Greek or calculus – J.N.] ... calculus ought to have been compulsory for me. One ought, after all, to be initiated into the life of the world in which one is going to live. I was going to live in the Western World ... and the calculus, like the full-rigged sailing ship, is ... one of the characteristic expressions of the modern Western genius.⁷

² Scholastic theologians have received bad historical press. Although they did err in some aspects of theology, they deposited an indispensable heritage for Western civilization (especially in science and mathematics).

³ Howard Eves, *An Introduction to the History of Mathematics* (New York: Holt, Rhinehart and Winston, [1953, 1964, 1969] 1976), p. 213.

⁴ Stanley L. Jaki, *The Road of Science and the Ways to God* (Edinburgh: Scottish Academic Press, 1978), p. 157.

⁵ Carl Boyer, *The History of the Calculus and Its Conceptual Development* (New York: Dover Publications, [1949] 1959), p. 65.

⁶ *Ibid.*, pp. 70-71.

⁷ Arnold Toynbee, *Experiences* (New York: Oxford University Press, 1969), pp. 12-13.

A CASE FOR CALCULUS

BY JAMES D. NICKEL

Using Toynbee's words, the "characteristic expression of the modern Western genius" finds its roots in Biblical theology. Without the Biblical view of the infinite God, Western man (with his culture impacted by the Gospel of Christ) could never have embraced the infinitesimal nature of the calculus. Christ is the Savior, in an historical sense, and Lord, in an epistemic sense, of science and mathematics.⁸

For the calculus to be successfully launched, it needed an acceptance and use of the concept of infinity, symbolic algebra, coordinate or analytic geometry (along with trigonometry), and the presence of reliable measuring tools (including mechanical clocks).⁹ All of these ideas and instruments were on the "launching pad" in Western Europe at the dawn of the 17th century. The scientists of this century were trying to solve a whole new group of problems and the calculus was developed to quantify and resolve the following:

1. The study of the motion of celestial bodies.
2. The study of projectile motion and rays of light striking the surface of a lens (of telescopes). To do this, they had to determine of tangent lines to various curves. Why? These lines represent the *direction* of the curve at the tangent point. A problem of pure geometry (tangent lines) became of great importance for scientific applications.
3. Optimization or maxima and minima problems. In warfare applications, a method was needed to determine the maximum range and angle of elevation for artillery cannon. Concerning planetary motion, a method was needed for determining the maximum and minimum distances of a planet from the Sun.
4. The study of lengths of curves (e.g., the distance covered by a planet (moving in an elliptical orbit) in a given period of time), the areas and volumes of figures bounded by curves and surfaces, the centers of gravity of bodies, and the gravitational attraction that a planet exerts on another planet.

Many men contributed to the development of the calculus. We can only list them now. First, the medieval heritage was transmitted through Nicholas of Cusa (1401-1464), Leonardo da Vinci (1452-1519), Niccolò Tartaglia (ca. 1499-1557), Geronimo Cardano (1501-1576), Rafael Bombelli (ca. 1526-1573), François Viète (1540-1603), Simon Stevin (1548-1620), Galileo Galilei (1564-1642), Johannes Kepler (1571-1630), and Evangelista Torricelli (1608-1647). Building on this foundation were Pierre de Fermat (1601-1665), René Descartes (1596-1650), Blaise Pascal (1623-1662), Gilles Persone de Roberval (1602-1675), Bonaventura Cavalieri (1598-1647), Isaac Barrow (1630-1677), James Gregory (1638-1675), Christian Huygens (1629-1695), John Wallis (1616-1703), Sir Isaac Newton (1642-1727), and Gottfried Wilhelm Leibniz (1646-1716).¹⁰

From the late 17th and lasting throughout the 18th century, the calculus was refined by Jakob Bernoulli (1654-1705), Johann Bernoulli (1667-1748), Michel Rolle (1652-1719), Brook Taylor (1685-1731), Colin Maclaurin (1698-1746)¹¹, Leonhard Euler (1707-1783), Jean Le Rond d'Alembert (1717-1783), and Joseph-Louis Lagrange (1736-1813).

In the 19th century, Bernhard Bolzano (1781-1848), Augustin-Louis Cauchy (1789-1857), Karl Weierstrass (1815-1897), Georg Friedrich Riemann (1826-1866), and Julius Wilhelm Richard Dedekind (1831-1916) made final clarifications (in the logical and rigorous sense).

Every textbook on calculus today borrows, more or less, from Euler.

William McGowen Priestley,
Calculus: A Liberal Art, p. 302.

⁸ See Stanley L. Jaki, *The Savior of Science* (Grand Rapids: Eerdmans, 2000).

⁹ See Donald Cardwell, *Wheels, Clocks, and Rockets: A History of Technology* (New York: W. W. Norton, 1995). Cardwell documents the strategic advances in technology that were made during the medieval period (also known as "the age of faith").

¹⁰ Both Newton and Leibniz (pronounced "liebnits") are considered to be the immediate co-founders of the calculus. Newton was the first to "put the ideas together" while Leibniz was the first to publish his ideas. The great controversy of their time was over who was to receive the honor of priority in the founding of the calculus.

¹¹ In the introduction to one of his books, Colin Maclaurin, a Scot, wrote that he undertook his labors to understand and bring forth the glory of God's creation.

A CASE FOR CALCULUS

BY JAMES D. NICKEL

Calculus is Latin for pebble and it carries the meaning of counting or calculation. The new concepts introduced by this branch of mathematics are the derivative and the integral. Both concepts are founded upon the limit concept, namely the *convergence of an infinite series to a limiting value*.

Let's begin our exploration!

A CASE FOR CALCULUS

BY JAMES D. NICKEL

2. CATCH A FALLING STAR

“Catch a falling star and put it in your pocket. Never let it fade away...” were words of a song sung by Perry Como (1913-2001) in the 1950s. Okay, that ages me since probably none of you, my readers, have ever heard of Perry Como (for connections sake, both Como and Elvis Presley (1935-1977) sang hit songs in the 1950s). Anyhow, it’s a catchy phrase, isn’t it?

Further dim chambers lighted by sullen, sulphurous fires were reputed to contain a dragon called the ‘Differential Calculus.’
Winston Churchill, “Examinations,”
My Early Life (1874-1904), p. 26.

The analysis of falling motion will be the goal of this section. In review, the function concept is the backbone of mathematics. A function quantifies the relationship or rule between two variables such as money in a bank and time or distance and time. We can also (1) create a table of functional values and (2) plot the curve that describes a function. The table represents the fact that a function is a pair of columns of numbers. A function maps a number in the first column (representing the independent variable) to a number in the second column (representing the dependent variable). In this table, the first column *has no number repeated*. As a rule, a function associates to each number in the first column to *exactly one* number in the second column. We can picture this correspondence as going *from* a horizontal number to a vertical number (on the x-y Cartesian coordinate plane). As a graph, a function is a curve that *no vertical*

line crosses more than once. These three descriptions, (1) columns, (2) correspondence, and (3) curve, express the same idea. With a little more analysis, we can see that there exists a marvelous unity in diversity in these three representations. The function is one idea expressed in a three-fold interplay. First, the columnar representation reflects the *static* (discrete) or Greek way of looking at the cosmos. Second, the rule of correspondence representation reflects a pure *kinematic* or *dynamic* view. Third, the curve puts the kinematic view into a *geometric* representation (with a flavor of continuity in terms of the real number continuum).

Pair of columns

1	45
2	32
3	31
4	40

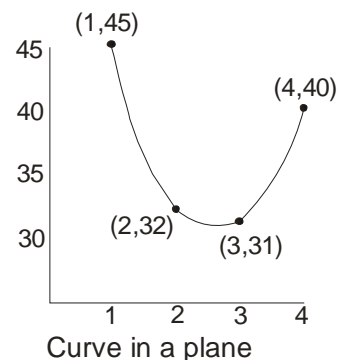
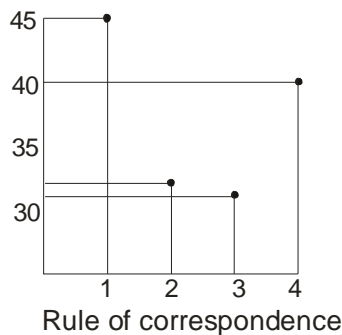

As we shall see in our subsequent explorations, the calculus is ultimately a study of fluid motion and the representation of a function on the Cartesian coordinate graph maps that motion in such a way that it can be analyzed “point by point.” The calculus is a pristine tool that can be used to represent the wonderful interplay between the static and the dynamic, the discrete and the continuous.

The graph of the function $y = f(x) = 2^x$, where x is only integers has “elbows” in it. With the introduction of fractional exponents, the charts smooth out to a degree. Archimedes tried to estimate the circumference of a circle (and, by implication, the value of π) by inscribing it and circumscribing it with a regular polygon of 96 sides. Our graphs, being pictures, are never capable of describing a function completely. We need a

A CASE FOR CALCULUS

BY JAMES D. NICKEL

more precise instrument or method of understanding the behavior of curves to any desired degree of accuracy. The *derivative* is such a tool.¹²

The derivative is defined as the limiting value of the ratio of the change in the dependent value of a function to the corresponding change in its independent variable. You encounter the derivative every time you calculate the slope of a straight line. The definition of the slope of a line is the ratio of the rise (change in dependent variable) over the run (change in the independent variable). Given two points on a straight line, (x_1, y_1) and (x_2, y_2) , we define the slope, a , of a straight line as:

$$a = \frac{\Delta y}{\Delta x} = \frac{y_2 - y_1}{x_2 - x_1}$$

The Greek letter Δ means “change in.” The derivative of a function can also be defined as the slope of the graph of the *function at a given point*. Note the phrase “given point.” With a straight line, we need two points to determine the slope. To find the slope at a given point in the calculus, *we take two points extremely (or infinitesimally) close to each other*.

For example, consider a small portion of the line representing the function $y = f(x) = 2x$ as revealed in the figure at right. We want to find the slope of the line at a point, say $x_1 = 2$. Let y_1 be the value of the function at this point; hence $y_1 = 2x_1 = 4$. If we just consider the slope at this coordinate $(2, 4)$, we run into trouble. At that instant, there is no change in y (Δy) and no change in x (Δx). No change in y implies $\Delta y = 0$ and no change in x implies $\Delta x = 0$. The slope therefore is:

$$\frac{\Delta y}{\Delta x} = \frac{0}{0}$$

This expression is meaningless because “*Thou shalt not divide by 0.*” Here is where the founders of the calculus (Leibniz primarily) introduced the concept of the infinitesimal (also called the *method of increments*¹³). Let’s choose another coordinate (x_2, y_2) and let $\Delta x = x_2 - x_1 = x_2 - 2$ and $\Delta y = y_2 - y_1 = y_2 - 4$. Therefore, at (x_2, y_2) we get:

$$y_2 = 2x_2$$

Since $\Delta y = y_2 - 4$, then $y_2 = \Delta y + 4$. Since $\Delta x = x_2 - 2$, then $x_2 = \Delta x + 2$. By substitution, we get this equation:

$$\Delta y + 4 = 2(\Delta x + 2) = 2\Delta x + 4$$

Since $\Delta y + 4 = 2\Delta x + 4$, we can subtract 4 from both sides of the equation and get:

$$\Delta y = 2\Delta x$$

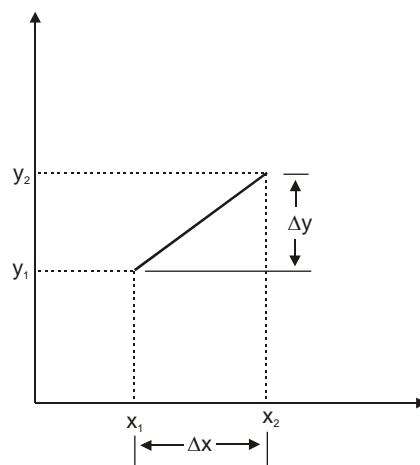

¹² Other words for derivative are the differential coefficient (meaning “difference number”) or fluxion (Isaac Newton’s word). Fluxion, in Latin, means “a flow or flowing.”

¹³ An increment means “a very small increase or addition.”

A CASE FOR CALCULUS

BY JAMES D. NICKEL

This equation states that the “change in y ” is always 2 times the “change in x .” Since the slope is defined as $\frac{\Delta y}{\Delta x}$, we get:

$$\frac{\Delta y}{\Delta x} = 2$$

As we let Δx get smaller and smaller, Δy gets smaller and smaller. Yet, no matter how infinitesimally small we let Δx get, the ratio of $\frac{\Delta y}{\Delta x}$ is always 2. 2 is the *limiting value of the ratio of the change in the dependent value of a*

function to the corresponding change in its independent variable. In other words, the limit of $\frac{\Delta y}{\Delta x}$ as Δx approaches 0 is

2. By using the limit concept in this way, the founders of the calculus *avoided division by 0*. In your study of the convergence of an infinite series, you should have met the limit concept and limit symbol (\lim). Here is how it looks in this case:

$$\lim_{\Delta x \rightarrow 0} \frac{\Delta y}{\Delta x} = 2$$

This also means that the slope of the line $y = 2x$ is 2 *for every given point on the straight line*. Hence, the derivative, symbolized as y' (say “ y prime” meaning “*instantaneous rate of change*”), of the function $y = 2x$ is:

$$y' = \lim_{\Delta x \rightarrow 0} \frac{\Delta y}{\Delta x} = 2$$

Congratulations! You have solved your first problem in the calculus. Not the “sulphurous” dragon Churchill thought it was, was it? It is as easy as calculating the slope. We can derive a general formula for calculating the derivative of any linear function as follows:

$$\text{If } y = ax + b, \text{ then } y' = a$$

The French mathematician Joseph-Louis Lagrange (1736-1813) used this method of denoting the derivative (y'). Other mathematicians used other symbols. Isaac Newton used the dot notation \dot{y} (say “ y dot”).

Gottfried Wilhelm Leibniz symbolized the derivative as $\frac{dy}{dx}$. This symbol means “the ratio of the change in y over the change in x ” or “a little bit of y over a little bit of x ” and we say “ dy over dx ”. Leonhard Euler symbolized a function of x as $f(x)$ (say “ f of x ”) where the letter f stands for function or “the rule.” In the case of our straight line, $f(x) = ax + b$. Euler wrote the derivative as $f'(x)$ (say “ f prime of x ”).

There is no agreed convention on the use of these symbols. Newton’s way is used the least (although, because Newton was primarily a physicist, the dot notation is still used in some physics textbooks in his honor).

What would be the derivative of $y = 3$? The graph of this relationship is a straight line parallel to the x -axis intercepting the y -axis at $(0, 3)$. What is the slope of

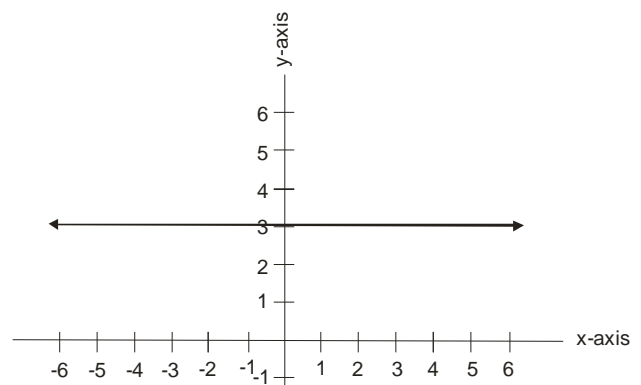

Copyright © 2007

www.biblicalchristianworldview.net

A CASE FOR CALCULUS

BY JAMES D. NICKEL

this line? 0, because the rise, Δy , is always 0. As we let the run, Δx , approach 0, the ratio of $\frac{\Delta y}{\Delta x} = 0$. In general, if $y = b$, then $y' = 0$. The derivative of a constant is always 0.

Physically, the straight line can picture *constant* speed or velocity.¹⁴ It was in the analysis of the *dynamism* of motion (or flow) that Newton interpreted the derivative concept. He called it the “method of fluxions.” He denoted the variable x as the *fluent* and when he calculated the rate of change of a variable, he used the expression “finding the fluxion of a given fluent.” The variable of time (seen as a flowing continuum) formed the basis of his physical theories.

Let’s say that I’m driving my car down a freeway. At 2:00 PM my odometer reading is 50,250. Three hours later, my *odometer* (Greek for “measure of the way”) reading is 50,430. Let’s assume that I had my cruise control button turned on during these three hours. Here’s a table reflecting the situation:

t (hours)	$t_1 = 2:00$ PM	$t_2 = 5:00$ PM
d (distance)	$d_1 = 50,250$	$d_2 = 50,430$

How fast was I driving? In other words, what was my velocity, v ? We find velocity by calculating the ratio of the change in distance (Δd) over the change in time (Δt):

$$v = \frac{\Delta d}{\Delta t} = \frac{d_2 - d_1}{t_2 - t_1} = \frac{50,430 - 50,250}{5 - 2} = \frac{180}{3} = 60$$

In general:

$$v = \frac{\Delta d}{\Delta t} = \frac{d_2 - d_1}{t_2 - t_1}$$

So, if our velocity is constant, then the graph of the situation is a straight line and the velocity, which is the slope of the line, is the derivative. In real life, however, velocity is not steady (it is constantly changing) so things are not this simple. We do use this formula to determine our *average*

velocity over time ($r = \frac{d}{t}$ where r = average rate, d = distance traveled, and t = time of travel).

Calculus studies velocity *at an instant*. In other words, calculus looks at the *speedometer* (measure of speed) and tells us how fast we are driving at a given instant of time.

Since velocity is a vector, then it can be negative. What would that mean? In the case of a car, it would mean driving backwards. If we throw a stone straight up, its velocity is positive as it travels upward; negative as it travels downward.

Now let’s consider motion where velocity is changing; i.e., our falling star. Instead of stars fal-

Alice looked around her in great surprise. “Why I do believe we’ve been under this tree the whole time! Everything’s just as it was!”

“Of course it is,” said the Queen.

“What would you have it?”

“Well, in our country,” said Alice, still panting a little, “you’d generally get to somewhere else – if you ran very fast for a long time as we’ve been doing.”

“A very slow sort of country!” said the Queen. “Now, here, you see, it takes all the running you can do, to keep in the same place.”

Charles Dodgson (Lewis Carroll)
Through the Looking Glass

¹⁴ Remember that speed is a scalar quantity in physics while velocity is a vector (magnitude *and* direction) quantity.

A CASE FOR CALCULUS

BY JAMES D. NICKEL

ling from the sky, we will consider Mr. Delta dropping a stone from the top of a building. How can we describe this situation? Enter the Italian mathematician Galileo Galilei (1564-1642). He explained his motivation for scientific study in these comments to the Grand Duchess Christina in 1615:

And to prohibit the whole science would be but to censure a hundred passages of holy Scripture which teach us that the glory and greatness of Almighty God are marvelously discerned in all his works and divinely read in the open book of heaven. For let no one believe that reading the lofty concepts written in that book leads to nothing further than the mere seeing of the splendor of the sun and the stars and their rising and setting, which is as far as the eyes of brutes and of the vulgar can penetrate. Within its pages are couched mysteries so profound and concepts so sublime that the vigils, labors, and studies of hundreds upon hundreds of the most acute minds have still not pierced them, even after continual investigations for thousands of years.¹⁵

In the *Assayer* (1623), he wrote with convincing authority linking the study of God's works to the principles of mathematics:

Philosophy is written in this grand book, which stands continually open to our gaze. But the book cannot be understood unless one first learns to comprehend the language and read the letters in which it is composed. It is written in the language of mathematics, and its characters are triangles, circles, and other geometrical figures without which it is humanly impossible to understand a single word of it; without these, one wanders about in a dark labyrinth.¹⁶

Stanley L. Jaki summarizes Galileo's foundations for scientific work:

The creative science of Galileo was anchored in his belief in the full rationality of the universe as the product of the fully rational Creator, whose finest product was the human mind, which shared in the rationality of its Creator.¹⁷

Galileo's analytical skills incorporated three principles in his study of the "grand book of God's creation." They are:

1. Obtain basic principles through observation and experimentation. Sometimes his experiments were "thought" experiments based upon what he observed.
2. Major on the major. That is, strip away incidental or minor effects. He tried to understand what was happening with falling objects by stripping away air resistance (i.e., he assumed they were falling in a vacuum).
3. Apply the derived principles and other mathematical demonstrations back to the real world with all of its limitations (i.e., air resistance).

Above all, Galileo proposed to seek *quantitative* descriptions in terms of mathematical equations and formulas. His commitment to quantitative analysis was the fruit of the 1,000 years of the leavening influence of the Christian Gospel in Europe (since the fall of Rome). His appreciation of an orderly and understandable creation presupposes the "God who created everything according measure, number and weight" (Wisdom of Solomon 11:20-21), even in a world of motion.¹⁸

¹⁵ Galileo Galilei, *Discoveries and Opinions of Galileo*, trans. Stillman Drake (Garden City: Doubleday, 1957), p. 196.

¹⁶ *Ibid.*, pp. 237-238.

¹⁷ Jaki, *The Road of Science and the Ways to God*, p. 106.

¹⁸ The *Wisdom of Solomon* is a book in the apocrypha (accepted by Roman Catholics as part of the canon of Scripture). In Latin, "measure, number, and weight" is "*omnia in mensura, numero et pondere disposuisti.*" This phrase was the *most often quoted and alluded to phrase in Medieval Latin texts*. See E. R. Curtius, *European Literature and the Latin Middle Ages*, trans. W. R. Trask (London: Routledge

A CASE FOR CALCULUS

BY JAMES D. NICKEL

Let's envision Mr. Delta as he drops a stone from the top of a building. As Professor Galileo watches, he first notices that the stone's velocity is *not* constant; i.e., *it increases with time*. Stop the motion for a second! Freeze the frame! At the juncture, Galileo's theorizing (now called the theory of *inertia*¹⁹) departs from the ancient Greek theory of motion, popularized by Aristotle (384-322 BC). Among other dicta, Aristotle postulated that an object, like a thrown ball, keeps moving only as long as something was actually in contact with it, imparting motion to it all the time. Whatever this "something" was (Aristotle thought it was "air" closing behind the ball), he said that it continually pushed the object along.²⁰

The theologian John Philoponus (ca. 500), on the basis of Christian convictions, first challenged this idea in the 6th century.²¹ Contrary to Aristotelian dogma (and *amazingly similar* to Galileo's "findings"), Philoponus resolved that:²²

1. All bodies would move in a vacuum with the same speed regardless of their weight (or mass).
2. Bodies of differing weights would, falling from the same height, hit the ground at the same time. This is easy to validate experimentally (something Aristotle never tried).
3. Projectiles move across the air, not because the air keeps closing behind them, but because they were imparted with a "quantity" of motion, an "oomph," that is technically called *momentum*.

The ideas of Philoponus were transmitted into the thinking of some key medieval theologians, particularly the French theologians Jean Buridan (ca. 1295-1358) and Nicole Oresme (ca. 1323-1382), via the work of the Arabic thinkers and translators.²³ These two medieval scholars refined the thoughts of Philoponus, especially the elementary *impetus*²⁴ theory of motion (point 3) thus building the foundation for Galileo's work in momentum and inertia and Isaac Newton's (1642-1727) formulation of the first law of motion.²⁵

Mr. Delta interrupts, "Excuse me, this history lesson is illuminating but I'm still waiting for the stone to hit the ground." "Hold on for a few more minutes," replies Professor Galileo, "Let's flush out some mathematics before we start the motion again."

Concerning this falling motion, how did Galileo quantify this relationship? He sought to measure it with a mathematical formula. Noting that the velocity v increased in proportion to the lapse of time t , he wrote the equation:

$$v = kt$$

What was the value of k ? Using an ingenious method of rolling a ball down an inclined plane and measuring time elapsed with a water clock, Galileo determined the constant to be 32 feet per second every second (written 32 ft/sec²).²⁶ In the metric system, this is 9.8 meters/second every second (written 9.8 m/s²).²⁷ Isaac Newton later determined this quantity to be the *gravitational force* of the Earth pulling the stone down. Galileo's formula now became:

and Kegal Paul, 1953), p. 504. See also Ivor Grattan-Guinness, *The Rainbow of Mathematics: A History of the Mathematical Sciences* (New York: W. W. Norton, [1997] 2000), p. 127.

¹⁹ Inertia, from Latin, means "idleness." The theory of impetus is also called the theory of *momentum* (Latin for movement).

²⁰ Herbert Butterfield, *The Origins of Modern Science* (New York: The Macmillan Company, 1961), pp. 3-4.

²¹ Philoponus spent most of his adult life in Alexandria, Egypt.

²² Stanley Jaki, *Science and Creation: From Eternal Cycles to an Oscillating Universe* (Edinburgh: Scottish Academic Press, 1974), pp. 185-187.

²³ Fritz Zimmermann, "Philoponus's Impetus Theory in the Arabic Tradition," *Philoponus and the Rejection of Aristotelian Science*, ed. Richard Sorabji (Cornell: Cornell University Press, 1987).

²⁴ Impetus, in Latin, means "to attack against."

²⁵ Newton's first law of motion states that "every object persists in a state of rest or a state of uniform motion in a straight line unless acted upon by an external force that changes that initial state."

²⁶ In five significant figures, the gravitational acceleration on Earth is 32.174 ft/sec².

²⁷ In six significant figures, the gravitational acceleration on Earth is 9.80665 m/sec².

A CASE FOR CALCULUS

BY JAMES D. NICKEL

$$v = 32t$$

Galileo now considered the quantitative answer to another question: How far does the stone fall in a given time? He discovered that a ball rolling down an inclined plane covered a distance proportional to the square of the time. In other words, doubling the time increased the distance four-fold, tripling the time increased the distance nine-fold, and so on. For the free fall motion of a stone dropped from the top of a building, the equation relating distance d and time t is (where g = the gravitational force of the Earth acting upon the stone):

$$d = \frac{1}{2}gt^2$$

Since $g = 32$, we get:

$$d = 16t^2 \text{ (note, this is a quadratic equation)}$$

Let's construct a table for some values of t and then draw the graph:

t	0	1	2	3
d	0	16	64	144

This graph should be familiar to you. It is the right half of a “facing up” parabola. The left half mirrors the right half for negative values of t (which physically makes no sense in our situation). The ancient Greeks would never have considered that the parabola would quantitatively describe falling motion. Unlike the graph for constant velocity (a straight line), the graph of “ever increasing” velocity is sharply curved upward. The differential calculus gives us a tool whereby we can analyze this changing velocity; it tells us what the velocity is *at an instant in time*.²⁸

For now, let's assume that we do not know the equation $v = 32t$. Given the equation $d = 16t^2$, let's apply the *method of increments* to find the velocity of the falling stone since at $t = 2$ seconds. It is essential that you

understand the next few paragraphs. Examine them carefully and thoughtfully for the derivation of the derivative of a curved line is foundational to the calculus.

In the diagram, I have magnified a portion of the curve where $P(x_1, y_1)$ represents a point on the graph of $y = 16x^2$ (to remove confusion using the variable d , I have rewritten $d = 16t^2$ as $y = 16x^2$). At $x_1 = 2$ seconds, then $y_1 = 64$ feet. We next draw a line tangent to P and consider a nearby point T on that line. From this we get ΔPRT (Leibniz called this triangle the *characteristic triangle*). The two legs of this triangle, PR and RT , are *increments* in the x and y coordinates as we move from P to

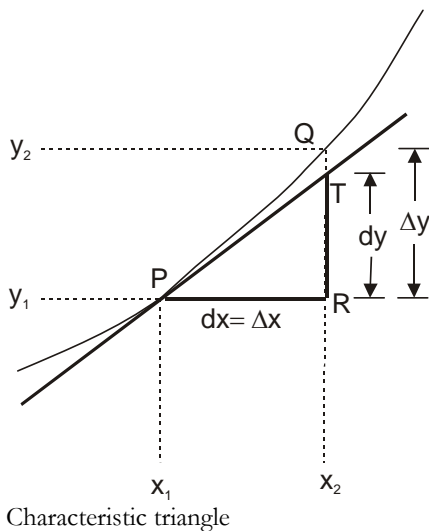
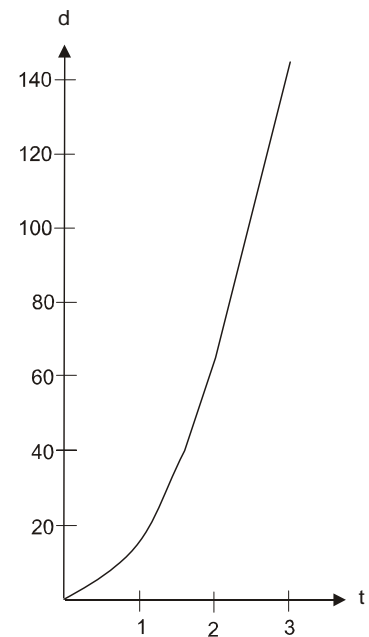

²⁸ The algebraic formula for falling motion and its associated graph on the Cartesian coordinate plane now describe *time and space* in the context of the *real number continuum*, a truly astounding connection, if you pause to think about it.

A CASE FOR CALCULUS

BY JAMES D. NICKEL

T. As we follow the procedure of Leibniz, he denoted these “little increases” as dx and dy respectively. He then argued that if we let dx and dy get sufficiently small, the tangent line to the graph at P *will be nearly identical to the graph of $y = 16x^2$ in this infinitesimally small neighborhood of P*. In more precise words, the *line segment \overline{PT}* will *nearly* be “in sync” with the *curved segment PQ*. To find the slope of the tangent line at P, the rise over run ratio becomes:

$$\frac{dy}{dx}$$

Leibniz now conjectured that since dx and dy are “little bits” or “infinitely small”, their ratio not only represents the slope of the tangent line at P but also *the steepness of the graph at P*. The ratio of $\frac{dy}{dx}$ *measures the rate of change of the curve at an instant*. This idea parallels Newton’s fluxions.

There is a flaw with this argument. The Irish prelate and philosopher George Berkeley (1685-1753) noted this in his satirical work *The Analyst* written in 1734. The tangent line will nearly be in sync with the curve at P; *it will not coincide with it*. If they coincide, then the characteristic triangle disappears meaning $dy = 0$ and $dx = 0$. The ratio again becomes $\frac{0}{0}$, a meaningless expression. In the 19th century, mathematicians fully developed the limit concept to circumvent this conundrum. Let’s see how they did it.

Referring again to the figure of the characteristic triangle, we choose two neighboring points P and Q (both on the *graph* of the curve $y = 16x^2$) and denote the sides \overline{PR} and \overline{RQ} of the triangle-like shape PRQ by Δx and Δy respectively. Note that $\Delta y > dy$ (because Q is above T) and that $\Delta x = dx$. The rise to run ratio of the curve between P and Q is:

$$\frac{\Delta y}{\Delta x}$$

As we let Δx approach 0 as a limit, the point Q moves back toward P along the curve. Δy also approaches 0 as a limit. The ratio of $\frac{\Delta y}{\Delta x}$ is called the *difference quotient* and it is the slope of the *secant*²⁹ line between P and Q. As Δx approaches 0, the secant line turns slightly (see the figure), until, at the limiting value, it coincides with the tangent line. Leibniz denoted this limit as the derivative $\frac{dy}{dx}$:

$$\frac{dy}{dx} = \lim_{\Delta x \rightarrow 0} \frac{\Delta y}{\Delta x}$$

Mr. Delta is waiting patiently at the top of the building for us to calculate the velocity of the stone at precisely 2 seconds after he dropped it. If $x_1 = 2$ seconds, then $y_1 = 64$ feet. We let $\Delta x = PR$ and $\Delta y = RQ$. We consider $x_2 = 2 + \Delta x$. Therefore, $y_2 = 64 + \Delta y$. Using the formula $y = 16x^2$ and making use of the binomial formula and the distributive rule over addition, we get:

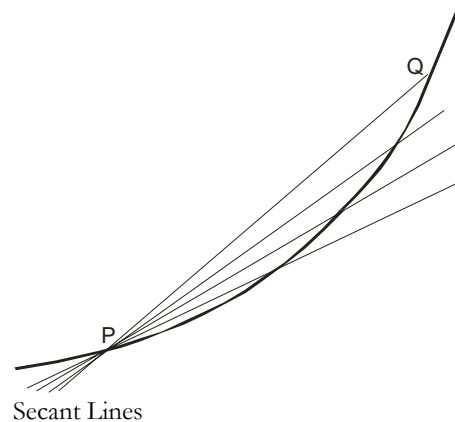

²⁹ A secant is a straight line that intersects a curve in two or more points. Secant, as we have already noted, is Latin meaning “to cut.”

A CASE FOR CALCULUS

BY JAMES D. NICKEL

$$y_2 = 64 + \Delta y = 16(2 + \Delta x)^2 = 16(4 + 4\Delta x + (\Delta x)^2) = 64 + 64\Delta x + 16(\Delta x)^2$$

Subtracting 64 from both sides of the equation, we get:

$$\Delta y = 64\Delta x + 16(\Delta x)^2$$

Now divide both sides of the equation by Δx . We get:

$$\frac{\Delta y}{\Delta x} = 64 + 16\Delta x$$

The ratio $\frac{\Delta y}{\Delta x}$ is the slope of PQ, the secant line. To find the derivative $\frac{dy}{dx}$ (or y') at $x = 2$, we find:

$$\frac{dy}{dx} = y' = \lim_{\Delta x \rightarrow 0} \frac{\Delta y}{\Delta x} = \lim_{\Delta x \rightarrow 0} (64 + 16\Delta x) = 64$$

Note that $16\Delta x$ drops out if we let Δx approach 0 (or gets infinitesimally small). Therefore, the velocity of the stone at 2 seconds is 64 feet/second (this is also the slope of the line tangent to the curve at P).

“Let the stone continue its fall!” cries Professor Galileo. “Thank you; it’s about *time*,” replies Mr. Delta. Let’s now resurrect Galileo’s formula for the velocity of a falling object:

$$v = 32t$$

If we let $t = 2$, then $v = 64$! We shall explore the connection between the two formulas $d = 16t^2$ and $v = 32t$ in the next section.

A CASE FOR CALCULUS

BY JAMES D. NICKEL

3. EXPLORING THE DERIVATIVE

Let's review the limit concept, the driving idea of the calculus, from a different angle. The idea behind a limit is the idea of getting closer and closer to something; the limit of a sequence of numbers is *converging* upon a point (a goal or target); i.e., *a number*. As a Biblical illustration, when Jesus said "The time is fulfilled, and the kingdom of God is at hand" (Mark 1:14-15), the Greek word for "at hand" is employing the limit concept. The long promised kingdom of Messiah is about to cross the *threshold* (or limit) of time and space. Using another metaphor, the wave of the promised and coming kingdom of God is about to crash upon the surf like a tsunami!

The limit concept can be corralled precisely and it took mathematicians nearly 2,000 years to do so. The man primarily responsible for this definition was the French mathematician and devout Roman Catholic Augustin Louis Cauchy (1780-1857). David Berlinski remarks about Cauchy's deep faith and conservative political commitments, "... the common assumption that scientific genius inevitably inclines a man toward agnosticism in his religious or political convictions is little more than a modern myth."³⁰

Let's start with a sequence of terms S_n that *converges* to a limit L . So far so good; i.e., too "easy." By converging to a limit, we mean that the sequence does so as it is *extended* towards infinity. Two key mathematical ideas are coordinated (or connected) in this unity of a "simple" idea: (1) extension of a sequence and (2) convergence to a limit. Rewording this definition, we can say that a sequence S_n converges to L if, by *extending* the sequence, the distance between S_n and L may be *indefinitely* decreased; i.e., that difference between S_n and L can be made *arbitrarily* small. Please take careful note that the mathematical operation of subtraction (taking the difference) is subordinated to the idea of "approaching a limit."



Augustin
Louis Cauchy
(Public Do-
main)

Imagine a huge magnet drawing an iron hammer inexorably toward itself. With every passing moment, the hammer gets closer and closer to the attracting force, the distance between the two being methodically sliced away. This suggests, as it has suggested to generations of mathematicians, that convergence hinges only upon some fixed but very, very small distance. Another word for this very, very small distance is the *infinitesimal*. What the ancient Greeks feared, *horror infiniti*, raises its head (either as a demon or an angel, depending upon your perception) and enters the conversation. The brilliance that Cauchy brought to the plate was that he tamed the Greek demon *horror infiniti* in his definition of a limit.

Cauchy set the Greek letter ε (epsilon) > 0 where $\varepsilon \in \mathbb{R}$ (i.e., ε is a positive real number). Returning to our magnet illustration, to say that the distance between the hammer and the attractive force may be indefinitely decreased is to say that whatever the value of ε , there will eventually be *some* electro-magnetic force that will attract the hammer to a position whose distance from the magnet is *less* than ε . In other words, whatever the distance between the magnet and the hammer currently is, the force from the magnet will draw the hammer *closer*. Carry this thought over to our sequence S_n . S_n converges toward a limit L if *whatever* the value of ε (where $\varepsilon > 0$), *some* point in the sequence can be found such that *there* and *for all points beyond* in the sequence, the intervening distance is *less than* ε . Let's state it again: For any positive number ε , there is some value (let's call it δ , the lower case Greek letter delta), such that for all terms in the sequence beyond δ , the distance between S_n and L is less than ε . It is both a mouthful and a revelation of Cauchy's genius.

³⁰ David Berlinski, *A Tour of the Calculus* (New York: Vintage Books, 1995), p. 126.

A CASE FOR CALCULUS

BY JAMES D. NICKEL

Let's set $S_n = \frac{1}{2^n}$.³¹ This sequence approaches $L = 0$ at the limit (it was one of Zeno's paradoxes but is now resolved in terms of infinitesimals). Let's arbitrarily set $\varepsilon = \frac{1}{23}$ (pretty close to L). The requisite δ then occurs at $\frac{1}{24}$. That is, for $\delta = \frac{1}{24}$ and all points in the sequence beyond, the difference between $\frac{1}{24}$ and 0 is *less than* $\frac{1}{23}$.

Read the previous five paragraphs again and again until everything "sinks in." Remember, it took mathematicians 2,000 years to finally grasp the infinitesimal.

In 1854, the German mathematician Karl Weierstrass (1815-1897) shored up some of the weak points of Cauchy's argument and defined the limit of a continuous function with a finely nuanced complexity that has since become a blight to the understanding of beginning calculus students (you will detect many of Cauchy's ideas about the limit of a sequence in this formal definition).

As a preliminary reminder, $|x - y|$ means the absolute value of $x - y$ or the distance, a positive amount, between x and y . Here comes a mouthful. Are you ready? In the figure, Weierstrass stated that $y = f(x)$ is continuous at $x = a$ [where $f(a) = b$]. Given any positive number ε , there exists a δ (i.e., whatever the choice of ε , some suitable choice of δ can be made) such that

for all x in the interval $|x - a| < \delta$, $|y - b| < \varepsilon$ (i.e., if the distance between x and a is less than δ , then the distance between y and b is less than ε). A function $f(x)$ has a limit b at $x = a$ if the same statement holds but with b replacing $f(a)$. Let's restate this definition another way: Given a continuous function $y = f(x)$, then $\lim_{x \rightarrow a} y = b$ means for every $\delta > 0$,

there exists a $\delta > 0$ such that if x differs from a by less than δ , then y differs from b by less than δ or there is some δ such that for all arguments that are within δ of a , y is within ε of b (inspect the figure for a picture of this rhetorical statement). Reducing this definition to pure symbols, $\forall \varepsilon > 0, \exists \delta > 0 \ni$ if $|x - a| < \delta$, then $|y - b| < \varepsilon$. In other words, for every challenge $\varepsilon > 0$ you can find a response $\delta > 0$ that meets a specific condition (the difference in distances).

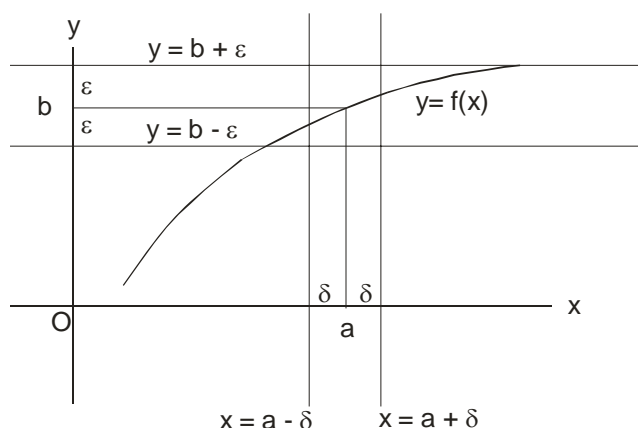

To say that the distance between y and b is less than ε is to say that y lies somewhere between $b + \varepsilon$ and $b - \varepsilon$. Using symbols, $b - \varepsilon < y < b + \varepsilon$ (as the figure reveals). Subtracting b from each part of the inequality gives us: $-\varepsilon < y - b < \varepsilon$. This inequality is the same as $|y - b| < \varepsilon$ where $|y - b|$ represents the absolute value of $y - b$.

³¹ We are talking about the sequence $\frac{1}{2}, \frac{1}{4}, \frac{1}{8}, \dots, \frac{1}{2^n}$.

A CASE FOR CALCULUS

BY JAMES D. NICKEL

Examplifying this definition with the function $y = f(x) = x^2$, y approaches 16 as a limit (the challenge) as x gets closer and closer to 4 (the response). After digesting the previous paragraph, I give you permission to take your brain to a doctor and get a prescription for stress relief.

The wonder of the derivative of a real valued function is that it determines exactly (*with perfect accuracy*) the behavior (or direction) of a continuous curve at each and every one of its infinitude of points. It is no wonder that mathematicians have applied the *method of increments* to virtually every kind of mathematical function. These derivatives have proven to be an essential tool in the hands of physicists in their analysis and work with these functions.

Let's return to the function $y = 16x^2$. This time we will consider negative values of x (to complete the full picture of the parabola). We can also calculate the derivative (by method of increments) of this function at several select points. Trust me with the derivative answers for the moment. Here is a table:

x	-8	-4	-2	0	2	4	8
$y = f(x)$	1024	256	64	0	64	256	1024
$y' = f'(x)$	-256	-128	-64	0	64	128	256

This table tells us several facts about the curve. The second row reveals the y -coordinate for each x -coordinate (we can plot these points). The third row reveals the slope of the line tangent to the curve at these points. By doing so, the derivative gives us information about the direction the curve is going and how steep it is. A slope of -256 means that the tangent line is pointing very steeply downward (\searrow) at the coordinate $(-8, 1024)$. A slope of -64 means that the tangent line is still pointing downward but not as steep (the curve is rounding out). A slope of 0 means that the tangent line at $(0, 0)$ is parallel (\rightarrow) to the x -axis (in fact, the tangent line is the x -axis in this case). The curve is turning directions at this point. Positive slopes mean that the tangent line is pointing upward (\nearrow). An analysis of the derivative tells us the shape of the parabola (without plotting its points). This is how a mathematician or physicist can quantify the behavior of any curve at any point.

Fortunately, we do not have to apply the method of increments at every point in order to determine the derivative at that point. We can use the method of increments to derive general formulas that are applicable to different types of functions. Let's see how this works.

We already determined how to find the derivative of a linear function. If $y = f(x) = ax + b$, then $y' = a$. Let's begin with a simple parabola, $y = f(x) = x^2$. Let's add Δx (a little bit of x) to x . We get:

$$y + \Delta y = (x + \Delta x)^2$$

Applying the binomial formula to the right side of the equation we get:

$$y + \Delta y = x^2 + 2x\Delta x + (\Delta x)^2$$

Since $y = x^2$, we can cancel these terms out from both sides of the equation. We get:

$$\Delta y = 2x\Delta x + (\Delta x)^2$$

Now divide both sides of the equation by Δx . We get:

$$\frac{\Delta y}{\Delta x} = 2x + \Delta x$$

Let's now let Δx get infinitesimally small. We get:

A CASE FOR CALCULUS

BY JAMES D. NICKEL

$$\frac{dy}{dx} = y' = \lim_{\Delta x \rightarrow 0} \frac{\Delta y}{\Delta x} = \lim_{\Delta x \rightarrow 0} (2x + \Delta x) = 2x$$

Hence, given $y = f(x) = x^2$, then $y' = f'(x) = 2x$.

Let's now differentiate $y = f(x) = x^3$. First add Δx to x . We get:

$$y + \Delta y = (x + \Delta x)^3$$

Applying the binomial formula to the right side of the equation we get:

$$y + \Delta y = x^3 + 3x^2\Delta x + 3x(\Delta x)^2 + (\Delta x)^3$$

Since $y = x^3$, we can cancel these terms out from both sides of the equation. We get:

$$\Delta y = 3x^2\Delta x + 3x(\Delta x)^2 + (\Delta x)^3$$

Now divide both sides of the equation by Δx . We get:

$$\frac{\Delta y}{\Delta x} = 3x^2 + 3x(\Delta x) + (\Delta x)^2$$

Let's now let Δx get infinitesimally small. We get:

$$\frac{dy}{dx} = y' = \lim_{\Delta x \rightarrow 0} \frac{\Delta y}{\Delta x} = \lim_{\Delta x \rightarrow 0} (3x^2 + 3x\Delta x + (\Delta x)^2) = 3x^2$$

Hence, given $y = f(x) = x^3$, then $y' = f'(x) = 3x^2$.

We can apply the same process to $y = x^4$. Try it on your own. $y' = f'(x) = 4x^3$.

What pattern do we see?

function	$y' = f'(x)$
$y = f(x) = x^2$	$2x$
$y = f(x) = x^3$	$3x^2$
$y = f(x) = x^4$	$4x^3$

Do you think differentiating x^5 gives $5x^4$? Differentiating x^6 gives $6x^5$? You are right. In general, if $y = x^n$, then $y' = f'(x) = nx^{n-1}$. What if n is negative or if n is a fraction? Try the method of increments when $n = -2$ and $n = \frac{1}{2}$ on your own for confirmation. You will find that the formula holds. It is amazing how knowledge of how to work with negative numbers and fractions bears such fruit in situations like these.

We have already noted that the derivative of a constant is 0. That means, if $y = f(x) = 5$, then $y' = f'(x) = 0$. The slope of the graph of $y = 5$ is a straight line parallel to the x -axis and intersects the y -axis at $(0, 5)$. The slope of this line is 0. What about differentiating $y = f(x) = x^2 + 5$? Intuitively, we would think to sum the derivatives of the individual terms; i.e., $2x + 0 = 2$. Let's apply the method of increments to make sure. First add Δx to x . We get:

$$y + \Delta y = (x + \Delta x)^2 + 5$$

Applying the binomial formula to the right side of the equation we get:

Copyright © 2007

www.biblicalchristianworldview.net

A CASE FOR CALCULUS

BY JAMES D. NICKEL

$$y + \Delta y = x^2 + 2x\Delta x + (\Delta x)^2 + 5$$

Since $y = x^2 + 5$, we can cancel these terms out from both sides of the equation. We get:

$$\Delta y = 2x\Delta x + (\Delta x)^2$$

We can proceed as before to calculate the derivative as $2x$.

What happens in the case of $y = f(x) = 16x^2$ (our falling stone formula). First add Δx to x . We get:

$$y + \Delta y = 16(x + \Delta x)^2$$

Applying the binomial formula to the right side of the equation we get:

$$y + \Delta y = 16(x^2 + 2x\Delta x + (\Delta x)^2)$$

Applying the distributive rule to the right side of the equation we get:

$$y + \Delta y = 16x^2 + 32x\Delta x + 16(\Delta x)^2$$

Since $y = 16x^2$, we can cancel these terms out from both sides of the equation. We get:

$$\Delta y = 32x\Delta x + 16(\Delta x)^2$$

Now divide both sides of the equation by Δx . We get:

$$\frac{\Delta y}{\Delta x} = 32x + 16(\Delta x)$$

Let's now let Δx get infinitesimally small. We get:

$$\frac{dy}{dx} = y' = \lim_{\Delta x \rightarrow 0} \frac{\Delta y}{\Delta x} = \lim_{\Delta x \rightarrow 0} (32x + 16\Delta x) = 32x$$

Hence, given $y = f(x) = 16x^2$, then $y' = f'(x) = 32x$. Here is our connection that we mentioned at the end of the last section. These equations match Galileo's observations. If $x =$ time, and $y =$ distance, then y' (the derivative of distance with respect to time) *is the formula for velocity*. That is, $v = y'$ where $v =$ velocity. The derivative in this case represents the rate at which the distance is changing in relation to time (exactly what the term velocity means). Now let $v = 32x$. What is the derivative of v ? That is, what is the rate at which the velocity is changing in relation to time? Since $v = 32x$ is a linear equation, then $v' = 32$. The constant 32 is the rate at which the velocity is increasing every second and it is called the *acceleration constant*. If $a =$ acceleration, then $a = v' = 32$. Galileo discovered this constant experimentally. It represents the pull of the force of Earth's gravity upon a falling object. The Earth pulls an object down at a rate of 32 feet per second every second (or 9.8 meters per second every second). We can note this in the following table for $y = f(x) = 16x^2$ for $x = 0, 1, 2, 3, 4, 5$ seconds.

x	0	1	2	3	4	5
y	0	16	64	144	256	400
v	0	32	64	128	160	192
a	0	32	32	32	32	32

A CASE FOR CALCULUS

BY JAMES D. NICKEL

Think what this means. *The differential calculus accounts for what happens when a stone is dropped from a building.* This is a dramatic connection between mathematics and the physical world.

In summary, the formula representing the *distance*, y , a stone falls in a certain amount of time, x , is:

$$y = f(x) = 16x^2$$

Differentiating y with respect to x we get the *velocity*, v , the rate at which the distance is changing in relation to time:

$$v = y' = f'(x) = 32x$$

Differentiating v with respect to x we get the *acceleration*, a , the rate at which the velocity is changing in relation to time:

$$a = v' = y'' = f''(x) = 32$$

Note the y'' and $f''(x)$ and symbol. It means the *second derivative*. y' , by implication, means the first derivative. Using the symbolism of Leibniz, the second derivative looks as follows:

$$a = \frac{d^2y}{dx^2}$$

The constant of acceleration, the second derivative of position, gives commentary to the way God's creation covenants work. He faithfully sustains the movement of bodies in the heavens and on the earth in such a way that the differential calculus, the second derivative of position, unveils a constant that is an echo of His covenant faithfulness.

You can differentiate any function as many times as you want. You might want to know that, in general, if $y = f(x) = ax^n$, then $y' = f'(x) = nax^{n-1}$. With this formula in hand, we can calculate the sixth derivative of $y = x^6$ as follows (I will not use f notation):

$$\begin{aligned}y' &= 6x^5 \text{ (first derivative)} \\y'' &= 30x^4 \text{ (second derivative)} \\y''' &= 120x^3 \text{ (third derivative)} \\y'''' &= 360x^2 \text{ (fourth derivative)} \\y''''' &= 720x \text{ (fifth derivative)} \\y'''''' &= 720 \text{ (sixth derivative)}\end{aligned}$$

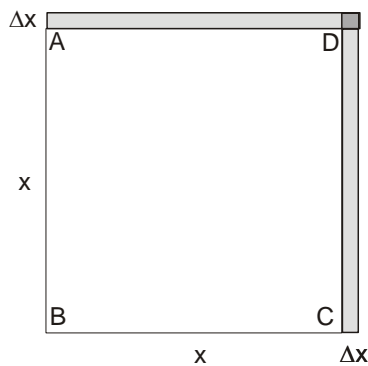

Although these derivatives can be computed in mere “mechanical fashion,” you always need to remember that the n^{th} derivative function expresses the instantaneous rate of change of the $(n - 1)^{\text{th}}$ function.

Let's inspect a few more elementary examples to see how the differential calculus helps us deal with totally different types of dependent quantities; i.e., how one principle connects to a diversity of applications.

If the length of the side of a square is x , then the area, y , of a square is given by the formula $y = f(x) = x^2$. Looks familiar, doesn't it? Let's consider what the increase in area would be if we increase the length of the side. Consider the square ABCD.

We have a square of length x . We next add a little bit, Δx , to the length. The area of the square has increased by Δy and we can represent this change in area as follows:

Copyright © 2007

www.biblicalchristianworldview.net

A CASE FOR CALCULUS

BY JAMES D. NICKEL

$$y + \Delta y = (x + \Delta x)^2$$

We have seen this before too. Applying the binomial formula to the right side of the equation we get:

$$y + \Delta y = x^2 + 2x\Delta x + (\Delta x)^2$$

What does this say with respect to the picture? x^2 represents the area of the original square. What does $2x\Delta x$ represent? $2x$ is twice the length of the original side of the square. On the picture, it represents the sum of AD and DC. Therefore, $2x\Delta x$ represents the area of the top strip and the right strip. Δx^2 represents the area of the small square at the top right. We want to find the rate of change in the area of the square based upon a change in its length. We compute this rate by differentiating $y = f(x) = x^2$. We get $y' = f'(x) = 2x$. The rate of change turns out to be the sum of AD and DC. This makes sense in our picture. As we let Δx get sufficiently small, the two strips converge to the length of AD and DC; i.e. $2x$. Also, as Δx gets sufficiently small, Δx^2 disappears. The derivative (the ratio of the growth of y to the growth of x) is *indeed* $2x$.

Let's try the same approach with the area of a circle. Let A = the area and r = the radius, then $A = f(r) = \pi r^2$. Differentiating, $A' = f'(r) = 2\pi r$. This is the formula for the circumference of the circle! This means that the rate at which the area of the circle increases when the radius r increases is *the measure of the circumference of the circle*. Here is a picture of the situation:

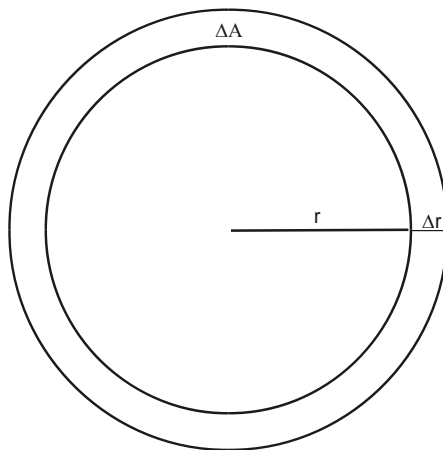

When the radius r is increased by an amount Δr , the area A of the circle increases by an amount ΔA . We can understand ΔA to mean the sum of circumferences and Δr as the number of such circumferences. The ratio, $\frac{\Delta A}{\Delta r}$, is then an *average* circumference in the region that looks like a washer or thin ring. As Δr approaches 0, this average circumference approaches the circumference with radius r . This circumference is the instantaneous rate with which the area increases at the given value of r .

Let's now consider the formula for circumference of a circle, $C = f(r) = 2\pi r$. Differentiating with respect to the radius r we get $C' = f'(r) = 2\pi$. This number is a constant (just like acceleration is a constant) and approximately equal to 6.28 (let's round off to 6). That means that every increase in r results in 6 times as much increase in the circumference. Consider placing a 25,000-mile long belt around the equator of the Earth (assumed to be a circle). It will be a snug fit. Let's allow for some "breathing room" by adding an extra 6 feet to the belt (we have increased the circumference). How far do you think the belt will be above the surface of the Earth? Most people think the distance would be a fraction of an inch at most. Wrong! By increasing the circumference, we have increased the radius. By how much? The derivative tells us that increas-

Copyright © 2007

www.biblicalchristianworldview.net

A CASE FOR CALCULUS

BY JAMES D. NICKEL

ing the radius results in 6 times as much increase in the circumference. The circumference has increased 6 feet, therefore the radius has increased $\frac{6\text{feet}}{6} = 1$ foot! The belt now hovers one foot over the equator.

Let's show this mathematically. Given $C = 2\pi r$, then $r = \frac{C}{2\pi}$. That means that the radius is about $\frac{1}{6}$ of the circumference; i.e. $r = \frac{C}{6}$. If we add 6 to C, we now get:

$$r = \frac{C+6}{6} = \frac{C}{6} + \frac{6}{6} = \frac{C}{6} + 1$$

In other words, the radius r is what it was before, $\frac{C}{6}$, + 1. The radius has increased by 1 foot. Note especially that C can be *any* measure, not just the measure of the circumference of the equator (25,000 miles in our case). If C measures 12 feet and you increase C by 6, the radius will again increase by *one foot*. Such is the *interpretive power* that the derivative of the circumference of the circle provides for us.

We have calculated many derivative formulas so far in this lesson. They have all been of polynomial functions. In closing, let's consider taking the derivative of two other types of functions, the exponential e^x and a few of the circular or trigonometric functions.

Let's first consider taking the derivative of $y = f(x) = e^x$. To do this, we can first write e^x as follows:

$$y = e^x = \lim_{n \rightarrow \infty} \left(1 + \frac{x}{n} \right)^n = 1 + \frac{x}{1!} + \frac{x^2}{2!} + \frac{x^3}{3!} + \frac{x^4}{4!} + \dots$$

Here we have, in essence, a series of polynomial functions. Taking the derivative of $y = f(x) = e^x$ is as easy as taking the derivative of each term of this polynomial (this is called the *sum rule for differentiation*). To do this we must remember that $y' = f'(x) = nx^{n-1}$. This gives us the rule for taking the derivative of each term except the first. Before we start computing, note that for each term except the first, the denominator is a constant. For example, we can rewrite $\frac{x^2}{2!}$ as:

$$\frac{1}{2}x^2$$

In general, if $y = f(x) = ax^n$, we can show that $y' = f'(x) = nax^{n-1}$. Therefore, we can calculate the derivative for this term as follows:

$$y = f(x) = \frac{1}{2}x^2 \Rightarrow y' = f'(x) = 2\left(\frac{1}{2}\right)x = x$$

This takes care of the third term. The derivative of the first term, 1, being a constant is 0. The derivative of the second term, x , is 1. The derivative of the fourth term is calculated as follows:

$$y = f(x) = \frac{1}{3 \cdot 2 \cdot 1}x^3 \Rightarrow y' = f'(x) = 3\left(\frac{1}{3 \cdot 2 \cdot 1}\right)x^2 = \frac{1}{2}x^2$$

The derivative of the fifth term follows the same procedure:

A CASE FOR CALCULUS

BY JAMES D. NICKEL

$$y = f(x) = \frac{1}{4 \cdot 3 \cdot 2 \cdot 1} x^4 \Rightarrow y' = f'(x) = 4 \left(\frac{1}{4 \cdot 3 \cdot 2 \cdot 1} \right) x^3 = \frac{1}{3!} x^3$$

Here is what we get after we sum all these derivatives:

$$y = f(x) = e^x \Rightarrow y' = f'(x) = 0 + 1 + \frac{x}{1!} + \frac{x^2}{2!} + \frac{x^3}{3!} + \frac{x^4}{4!} + \dots = e^x$$

This is astonishing. The derivative of e^x is e^x ! e^x is the only function in all of mathematics in which its derivative equals itself. This means that the instantaneous rate at which e^x changes is e^x . The central role of this function in mathematics and science is a direct consequence of this fact. One can find many phenomena in God's world in which the rate of change of some quantity is proportional to the quantity itself. We find this happening with the rate of decay of a radioactive substance. When a hot object is put into a cooler environment (e.g., hot cocoa on ice), the object cools at a rate proportional to the difference in temperatures (called Newton's law of cooling). When sound waves travel through any medium (air or otherwise), their intensity decreases in proportion with the distance from the source of the sound. Money compounded continuously (at every instant) grows proportionally with time. The growth of a population (given certain requirements and limitations) grows proportionately with time.

The computation of the derivation of e^x is quite easy compared to what we will try next; i.e., the derivative of circular or trigonometric functions. Let's see if we can do it. All that is required of you is patience and perseverance. Draw the diagrams yourself and work out the derivation along with me on a piece of paper.

Given $y = f(\theta) = \sin \theta$ (where θ is in radians), what would the derivative be? Given the unit circle (radius = 1) with angle θ (theta), then, by definition, $PA = \sin \theta$ and $OA = \cos \theta$. Note that as θ

changes from 0 to $\frac{\pi}{2}$ (remember $\frac{\pi}{2}$ radians equals 90°), $\sin \theta$ also

changes (from 0 to 1). In that same interval (0 to $\frac{\pi}{2}$), $\cos \theta$ changes

from 1 to 0. The \cos function and the \sin function are inverses of each other. How does $\sin \theta$ vary as θ varies? To find out, we must calculate the derivative of $y = f(\theta) = \sin \theta$.

Using the method of increments, we add $\Delta\theta$ to θ and determine what happens with $y + \Delta y = \sin(\theta + \Delta\theta)$. See the graph at right.

In the graph, we have increased θ by $\Delta\theta$. By doing so PA has *increased* to QB where $QB = \sin(\theta + \Delta\theta)$. At the same take OA has *decreased* to OB where $OB = \cos(\theta + \Delta\theta)$. Note also that $\Delta\theta$ represents the radian measure from P to Q . Also remember that $\Delta\theta$ is just a "little bit" or infinitesimally small. Let's now draw the tangent line l to the circle at point P and draw the right triangle ΔQDP . By one of Euclid's propositions (Book III, Proposition 18³²), we know that $l \perp \overline{PO}$

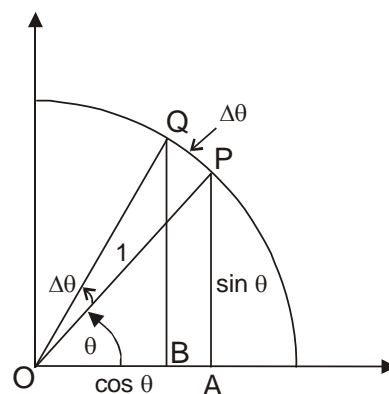
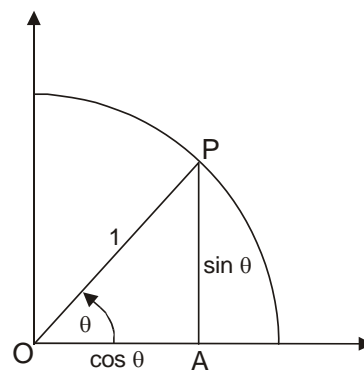

³² Heath, 2:44-45.

A CASE FOR CALCULUS

BY JAMES D. NICKEL

(remember, the symbol \perp means “perpendicular to”). That means that $\angle QPO = 90^\circ$. Since $\triangle PAO$ is a right triangle, we know that:

$\angle OPA = 90^\circ - \theta$. Why?

Since the sum of the measures of the angles in a triangle equal 180° , then $\theta + \angle OPA + \angle PAO = 180^\circ$.

Since $\angle PAO = 90^\circ$, then we can substitute and get $\theta + \angle OPA + 90^\circ = 180^\circ$.

Subtracting 90° from both sides of the equation, we get $\theta + \angle OPA = 90^\circ$.

Solving for $\angle OPA$ we get $\angle OPA = 90^\circ - \theta$.

Since $\theta + \angle OPA = 90^\circ$, then θ and $\angle OPA$ are called complementary angles. Follow closely now; don't give up and keep focused. We have constructed \overline{DP} such that it is parallel to \overline{OA} (in symbols, $\overline{DP} \parallel \overline{OA}$). Another one of Euclid's propositions states that if two parallel lines are cut by transversal³³ (\overline{PO} in this instance), then alternate interior angles are equal (Book I, Proposition 29).³⁴ In this case, $\theta = \angle DPO$. Since $\angle QPO$ is a right angle (i.e., $\angle QPO = 90^\circ$), then $\angle DPO$ and $\angle DPQ$ are complementary; i.e., $\angle DPQ = 90 - \theta$. Since $\triangle QDP$ is a right triangle, then $\angle DPQ$ and $\angle DQP$ are complementary; i.e., $\angle DQP = \theta$. Are you still with me? We have now have two triangles, $\triangle QDP$ and $\triangle PAO$ that are similar to each other (in symbols, $\triangle QDP \sim \triangle PAO$). Now consider \overline{DQ} . What does it represent? *It represents the change in y (i.e., Δy) resulting from the change in θ (i.e., $\Delta\theta$).* In other words:

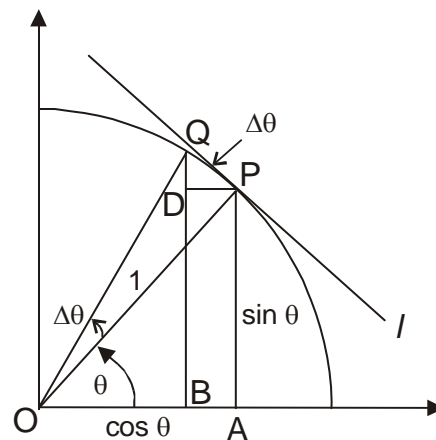

$$\frac{\Delta y}{\Delta\theta} = \frac{DQ}{\Delta\theta} = \frac{\sin(\theta + \Delta\theta) - \sin\theta}{\Delta\theta}$$

This is our derivative formula. In $\triangle QDP$, $\cos\theta = \frac{DQ}{\Delta\theta}$ (side adjacent over the hypotenuse). Note that as $\Delta\theta$ gets infinitesimally small, \overline{QP} (the hypotenuse) converges to $\Delta\theta$. Because $\triangle QDP \sim \triangle PAO$, then $\frac{DQ}{\Delta\theta} = \frac{OA}{PO}$. Since $PO = 1$ and $OA = \cos\theta$, then:

$$\frac{\Delta y}{\Delta\theta} = \frac{DQ}{\Delta\theta} = \frac{\sin(\theta + \Delta\theta) - \sin\theta}{\Delta\theta} = \frac{OA}{PO} = \frac{\cos\theta}{1} = \cos\theta$$

As we let $\Delta\theta$ approach 0 as a limit, then $y' = f'(\theta) = \cos\theta$. That means as θ increases, $\sin\theta$ increases at an instantaneous rate of $\cos\theta$. We can visualize this with the following graph:

³³ Transverse is Latin for “to turn across.” In mathematics, a transversal is a line or line segment that intersects a system of other lines (in our example, a system of parallel lines).

³⁴ Heath, 1:311-314.

A CASE FOR CALCULUS

BY JAMES D. NICKEL

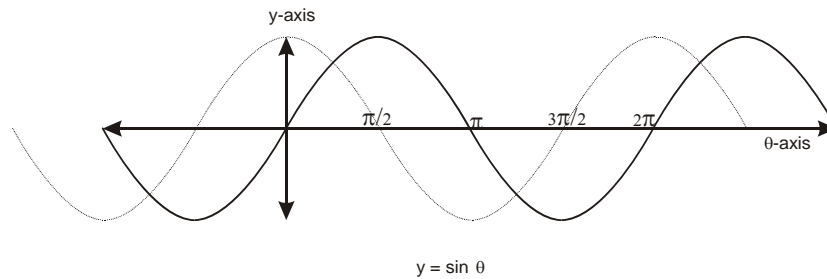

The solid line graph represents $y = f(\theta) = \sin \theta$ (the sine curve). The dotted line graph represents $y' = f'(\theta) = \cos \theta$ (the cosine curve). Note that when $\theta = 0$, then $\cos \theta = 1$. This means that the slope of the line tangent to the sine curve at 0 is 1. The cosine curve plots that derivative. When $\theta = \frac{\pi}{2}$, then $\cos \theta = 0$.

This means that the slope of the line tangent to the sine curve at $\frac{\pi}{2}$ is 0 (the slope is parallel to the θ -axis).

The cosine curve traces the derivative of the sine curve at every point on the sine curve.

By similar reasoning, we can calculate the derivative of $\cos \theta$. We let $y = f(\theta) = \cos \theta$. Then, $y' = f'(\theta) = -\sin \theta$.

Congratulations on following this classic mathematical argument. You have seen a *crème de la crème*³⁵ example of deductive analysis.

³⁵ *crème de la crème* is French for “superlative.”

A CASE FOR CALCULUS

BY JAMES D. NICKEL

4. MORE ON MOTION

Let's return to the motion of a falling body. From Galileo's experiments and the differential calculus we have three equations that connect time elapsed with position, velocity, and acceleration. They are:

Equation 1. $d = 16t^2$ (position function)

Equation 2. $v = d' = 32t$ (velocity function)

Equation 3. $a = v' = d'' = 32$ (acceleration constant)

These equations describe the motion of a stone dropped from the top of a building. Let's introduce a new concept, *initial velocity*. Initial velocity means the speed and direction that the object has at the beginning of the experiment. In our case, the initial velocity is zero since we are merely dropping the stone (not throwing it down). If we threw the stone down, it would reach the bottom faster because of its initial velocity.

We also must review the concept of velocity. By definition, velocity is a vector and a vector in physics reflects two attributes: (1) speed and (2) direction. How would the direction attribute apply to the velocity function, $v = 32t$? Direction, in our example, would be either up or down. Let's label upward direction as positive and downward direction as negative. Since we are dropping the stone and the force of gravity is pulling the stone down, we should *technically* rewrite our three equations as follows:

Equation 1. $d = -16t^2$ (position function)

Equation 2. $v = d' = -32t$ (velocity function)

Equation 3. $a = v' = d'' = -32$ (acceleration constant)

Equation 1 tells us how far (position) the stone falls *downward* in a given amount of time. Equation 2 tells us the velocity (in a *downward* direction) at each second. For example, at $t = 2$, $v = -64$. The stone is falling at a downward speed of 64 feet per second. Equation 3 tells us the *downward* pull of gravity on the stone.

How would we quantify this situation? We drop a stone from the top of a building 100 feet high. The equations would look as follows:

Equation 1. $d = 100 - 16t^2$ (position function)

Equation 2. $v = d' = -32t$ (velocity function)

Equation 3. $a = v' = d'' = -32$ (acceleration constant)

Equation 1 tells us the distance above the ground that the stone is at a given time. For example, after one second, $d = 84$; the stone is 84 feet above the ground. Since the derivative of a constant is 0, then Equations 2 and 3 do not change. This fact fits the situation perfectly. The downward velocity of the stone increases at a rate of 32 feet per second *irrespective* of the initial height (whether 100 or 1,000 feet).³⁶

How long will it take for the stone to reach the ground? When this happens, $d = 0$. So, we solve the following equation for t :

$$0 = 100 - 16t^2$$

Adding $16t^2$ to both sides of the equation, we get:

$$16t^2 = 100$$

Dividing both sides of the equation by 16, we get:

$$t^2 = 6.25$$

³⁶ Technically, however, the gravitational constant varies ever so slightly based upon the distance of the object from the center of the Earth.

A CASE FOR CALCULUS

BY JAMES D. NICKEL

Taking the square root of both sides, we get:

$$t = \pm\sqrt{6.25}$$

Solving for positive t (the negative root makes no physical sense), we get:

$$t = 2.5$$

Now let's apply some muscle to the situation. Let's throw the stone down from the top of the building of height 100 feet. Let's say that we throw the stone down with an initial velocity of 16 feet per second. What would our equations look like now?

Equation 1. $d = 100 - 16t - 16t^2$ (position function)

Equation 2. $v = d' = -16 - 32t$ (velocity function)

Equation 3. $a = v' = d'' = -32$ (acceleration constant)

Equation 1 describes the situation where $-16t$ represents the initial velocity (the extra push on the stone). After 1 second, the stone will be 68 feet above the ground (instead of 84 feet compared to when we just drop it). The extra 16 feet comes from the initial velocity. Equation 2 tells us that the velocity due to the force of gravity (32 feet per second) has an added velocity constant (16) due to the initial push. After 1 second, the stone's downward velocity is 48 feet per second (instead of 32 feet per second compared to when we just drop it). Again, Equation 3 (the derivative of the velocity function) resolves to the acceleration constant (as it always will do).

How long will it take for the stone to reach the ground? We solve Equation 1 for t when we set $d = 0$:

$$0 = 100 - 16t - 16t^2$$

We rearrange the terms of the quadratic equation in standard form as follows:

$$16t^2 + 16t - 100 = 0$$

Divide the equation by 4 to get:

$$4t^2 + 4t - 25 = 0$$

Applying the quadratic formula, we get:

$$t = \frac{-b \pm \sqrt{b^2 - 4ac}}{2a}$$
$$t = \frac{-4 \pm \sqrt{4^2 - 4(-100)}}{8}$$
$$t = \frac{-4 \pm \sqrt{16 + 400}}{8} = \frac{-4 \pm \sqrt{416}}{8} = \frac{-4 \pm 20.4}{8}$$

Solving for positive t , we get:

$$t = \frac{16.4}{8} = 2.05$$

True to our intuition, the stone reaches the ground 0.45 ($2.5 - 2.05$) seconds faster by throwing as compared to dropping.

Personally, heights make me dizzy. I'm taking the elevator down to ground level. Once on *terra firma* (Latin for "solid ground"), I pick up the stone and drop it into my "stone cannon." I point the cannon

Copyright © 2007

www.biblicalchristianworldview.net

A CASE FOR CALCULUS

BY JAMES D. NICKEL

straight up, ignite the gunpowder, and pull the trigger. Let's say that the cannon thrusts the stone upward with an initial velocity of 96 feet/second. How can I quantitatively describe this motion? Since we are initially thrusting the stone up, we have an initial positive velocity of 96 feet/second. Our equations look as follows:

Equation 1. $d = 96t - 16t^2$ (position function)

Equation 2. $v = d' = 96 - 32t$ (velocity function)

Equation 3. $a = v' = d'' = -32$ (acceleration constant)

Let's graph the position function and see what we get. It is a parabola facing downward:

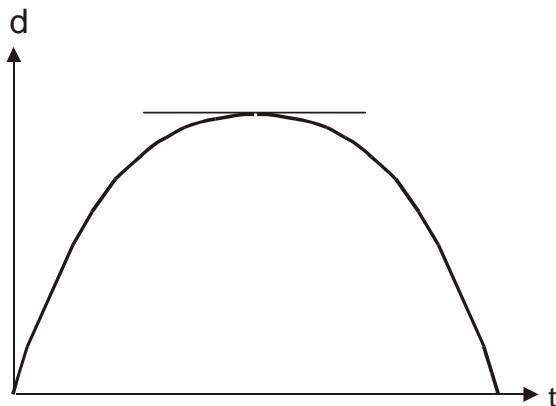

At $t = 0$, then $d = 0$. At this instant, I'm ready to light the match. After the cannon propels the stone upward, the graph traces the stone's position progress over time. The stone begins its upward path until it reaches a maximum height. At that point, the slope of the line tangent to the graph of the parabola is zero. As the stone ascended upward, the pull of gravity downward slows the velocity of the stone. For example, at time of $t = 1$, the velocity of the stone is 64 feet per second (from Equation 2). At the maximum height, the velocity of the stone is 0. At this position, the slope of the tangent line and the velocity is 0 (which is the meaning of the derivative). The stone then begins its "free fall" motion downward.

What is this *maximum* height and how long does it take the stone to reach it? We could create a table of Equation 1 and find out by trial and error or we could inspect Equation 2 (the velocity or first derivative function) and find out algebraically. We know that at the maximum height, the velocity is 0. From Equation 2, we get (we have set the first derivative equal to 0):

$$0 = 96 - 32t$$

Adding $32t$ to both sides of the equation, we get:

$$32t = 96$$

Dividing both sides of the equation by 32, we get:

$$t = 3$$

Three seconds after the stone leaves the cannon, it reaches its maximum height. What is this height? Substituting $t = 3$ into Equation 1, we get:

$$\begin{aligned}d &= 96(3) - 16(3)^2 \\d &= 288 - 144 = 144\end{aligned}$$

The maximum height that the stone reaches after three seconds is 144 feet. Try constructing a table of varying t from 0 to 6 to see how when $t = 3$, the height is at maximum.

Copyright © 2007

www.biblicalchristianworldview.net

A CASE FOR CALCULUS

BY JAMES D. NICKEL

You have just encountered one of the most important applications of the differential calculus; it is how the derivative resolves *optimization* (maximum or minimum) problems. Industrial engineers often confront problems of design optimization; i.e. which design costs the least or which design results in the highest production capabilities. These problems can be very difficult in terms of deriving the appropriate functional relationships. Once the equations are developed, then it is a simple matter of taking the derivative, setting it equal to zero, and solving for the unknown.

Let's take a simple example far removed from stone throwing (the neighbor across the street with his expansive and expensive bay windows is getting a little nervous). Let's visit to Mr. Farmer as he converses with Mr. City Slicker. Mr. City Slicker wants to build an ancient Egyptian amusement park on some property next to the Mr. Farmer's land. Mr. City Slicker is entertaining the nifty idea of transporting the park visitors around on camels. In fact, he has bought a herd of camels and wants to fence them in near a river that runs through his property. Mr. City Slicker can only afford 800 feet of fencing for his camel herd and he wants to enclose them in a rectangular field one side of which is bounded by the river. He finds a straight section of the river and figures that his idea is great because he doesn't have to worry about watering the camels. His problem is that he doesn't know how to get the most area out of his 800 feet of fencing. He needs to know what to do before he starts to dig holes for his fence posts.

For since the fabric of the universe is most perfect and the work of a most wise Creator, nothing at all takes place in the universe in which some rule of maximum or minimum does not appear.

Leonhard Euler (1707-1783)

"Mr. Farmer surely would know how to do this since he had such a nifty way of counting the number of cows in his pasture,"³⁷ thinks Mr. City Slicker to himself as he approaches Mr. Farmer's house and knocks on the screen door. Mr. Farmer listens to Mr. City Slicker explain the situation. At the end of the portrayal, Mr. Farmer pulls on his graying beard a few times in deep contemplative thought. Suddenly he exclaims, "Derivative!" He quickly retreats to his study. In the meantime, Mr. City Slicker stands in dumbfounded silence thinking,

"Did I hear him right? I'm sure that he said 'drive a Tiv.'" But I drive a Tercel! Is there a new model car that's out? And, how can driving a 'Tiv' solve my problem? I guess I'll have to trust Mr. Farmer because he sure knows how to count cows!"

Meanwhile, back in the study, Mr. Farmer is drawing a diagram. Let's peak over his shoulder to find out what he is doing. Fortunately for us, Mr. Farmer always thinks out loud when he works in his study so we get to hear his reasoning.

"Let's see," says Mr. Farmer, "I've got 800 feet of fence and three sides to work with. I've got to make a rectangular field for the camels so I'll let the width of the field be w . That takes care of two of the three sides and I've used up $2w$ feet of fence. I have $800 - 2w$ feet left. That's for the third side. The area of a rectangle is its length multiplied by its width so I've got this equation:"

$$A = w(800 - 2w) = 800w - 2w^2$$

³⁷ For the reader's information, Mr. Farmer determines the number of cows in his pasture by counting the number of legs and dividing by 4.

A CASE FOR CALCULUS

BY JAMES D. NICKEL

[Observer's note: This equation is just like the "stone cannon" equation (a parabola) except the context is entirely different. Here the unity in diversity principle appears again. Now back to Mr. Farmer's train of thought...]

"I'm sure glad they taught me calculus when they taught me how to count cows. I'll take the derivative of A and get:"

$$A' = 800 - 4w$$

"To get the maximum area I'll set the derivative equal to 0 and solve for w ."

$$0 = 800 - 4w$$

$$4w = 800$$

$$w = 200$$

"There you go. The width is 200 and the length is 400 [$800 - 2(200)$]. The area is maximal now; in fact, it will be 80,000 square feet. That should give Mr. City Slicker's camels plenty of room to graze."

Needless to say, Mr. City Slicker did not have to buy a new "Tiv." After Mr. Farmer informed Mr. City Slicker of the solution, Mr. City Slicker began to dig holes with his hole-post digger thinking all the time to himself, "There must be something to knowing how to count cows the way Mr. Farmer does."

A CASE FOR CALCULUS

BY JAMES D. NICKEL

5. REVERSING THE PROCESS

In scientific work, i.e., when physical problems are formulated mathematically, the given physical information usually leads to a *derived function* (i.e., a function that represents the rate of change or the derivative). In this context, the primary objective of the mathematical scientist is to find the original function of the derived function; i.e. to reverse the process. This method of reversing the process is called *anti-differentiation* or taking the *integral*.³⁸

Using our falling stone example, the process of integration starts from the velocity function and derives the position function. This is the reverse of differentiation, which starts from the position function and derives the velocity function. Note the table below:

Derivative	from position to velocity
Integral	from velocity to position

In this sense the integral is the inverse of the derivative and vice versa. Given the velocity function governing falling motion, $v = d' = -32t$, how can we derive the position function? We know that the position function must be of the form $d = f(t)$ where $f(t)$ means “a function of time.” We also know that, in general, if $y = f(x) = ax^2$ (given function), then $y' = f'(x) = 2ax$ (the derivative or derived function). Going “backwards,” since $d' = -32t$ (the velocity function), then $d = -16t^2$ (the position function).

We need to note an *important distinction* when taking the integral of a derived function. Note that if $y = f(x) = ax^2 + c$ (where c is a constant), then $y' = f'(x) = 2ax$. Therefore, if we are given the derived function $y' = f'(x) = 2ax$, then we do not know the value of c in $y = f(x) = ax^2 + c$. In our falling motion equation, $d = -16t^2 + 100$ means that we are dropping a stone from an initial height of 100 feet. It really does not matter from what height we drop the stone, the velocity function, $d' = -32t$, will still describe the motion of the stone. The *indefinite integral* takes this into account. Given $d' = -32t$, then $d = -16t^2 + c$ is the indefinite integral (also called the *primitive function*). The word “indefinite” implies that the constant c can be *any* value.

What happens if we start from the acceleration constant, $a = v' = -32$? Remember that this constant describes the instantaneous acceleration or the instantaneous rate of the change of velocity with respect to time of the falling object. What formula relates velocity to time? Note that if $y = f(x) = bx$, then $y' = f'(x) = b$. Therefore, the primitive function of the integral of $v' = -32$ is $v = -32t + c$. The constant c would describe the initial velocity of the stone (i.e., the velocity at which the stone is thrown down, a negative value, or thrown up, a positive value).

Here are some general formulas for calculating the integral of a derived function (based upon derivatives we have already calculated):

<i>Derived function</i>	<i>Indefinite Integral</i>
$y' = f'(x) = ax$	$y = f(x) = \frac{ax^2}{2} + c$
$y' = f'(x) = b$	$y = f(x) = bx + c$
$y' = f'(x) = ax + b$	$y = f(x) = \frac{ax^2}{2} + bx + c$

³⁸ Integral comes from the Medieval Latin *integralis* meaning “making up the whole.” The Latin word *integer* means “complete.” “Making up the whole” conceptualizes the idea of area, the basic idea of the integral calculus. Jakob Bernoulli (1654-1705) first used the word integral in its calculus sense in his book *Acta eruditorum* (1690). Historically, the concept of the integral was developed *before* the concept of the derivative.

A CASE FOR CALCULUS

BY JAMES D. NICKEL

<i>Derived function</i>	<i>Indefinite Integral</i>
$y' = f'(x) = ax^n$	$y = f(x) = \frac{ax^{n+1}}{n+1} + c$
$y' = f'(x) = \cos x$	$y = f(x) = \sin x + c$
$y' = f'(x) = \sin x$	$y = f(x) = -\cos x + c$
$y' = f'(x) = e^x$	$y = f(x) = e^x + c$

Knowing the velocity function, how can we determine the distance traveled (how far the stone has fallen) within a given amount of time? We are given:

$$v = d' = 32t$$

Since we want to find the distance an object falls, we will consider the point of release as the origin. The downward distance referenced as such can be considered to be a positive value.

If we know the position function, then the solution is easy. We calculate the distance, $d(0)$, at $t = 0$ (initial time) and then we calculate the distance, $d(t_1)$, at $t = t_1$. The difference, $d(t_1) - d(0)$, equals the distance the stone has fallen in t_1 seconds. Let's calculate the distance the stone has fallen at $t = 4$ seconds. Given the velocity function, we integrate the function to get the position function, which is:

$$d = 16t^2$$

origin

Distance is measured downward as positive. Therefore, the velocity function is positive:
 $v = 32t$

d

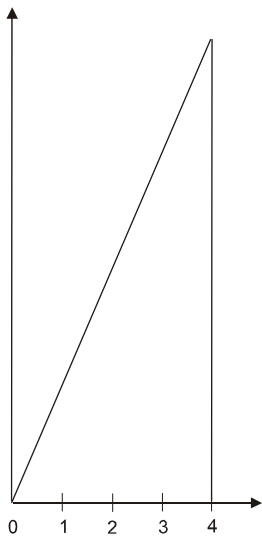

At $t = 0$, $d(0) = 0$. At $t = 4$, $d(4) = 256$. The difference, $d(4) - d(0)$, is $256 - 0 = 256$. The stone has fallen 256 feet in 4 seconds.

Now let's graph the velocity function $v = 32t$ from $t = 0$ to $t = 4$. Note that the graph is a straight line with slope of 32. If we consider the area under this straight line (from $t = 0$ to $t = 4$), we have a right triangle with base of 4 and a height of 128 (32×4). What is the area of this triangle? The formula for the area of a triangle is as follows:

$$A = \frac{1}{2}bh$$

Substituting $b = 4$ and $h = 128$, the area of this triangle is 256! What we have shown is that the *area* of the velocity function between two points gives us the *distance* the stone has fallen. Try the same technique (compare distance calculated by the position function with the area calculated by the velocity functions) for $t = 1, 2, 3, 5$, and 6 for confirmation. Here's a table of what you will find:

t	<i>Position Function</i> (distance fallen)	<i>Velocity Function</i> (area under the curve)
1	16	16
2	64	64
3	144	144

Copyright © 2007

www.biblicalchristianworldview.net

A CASE FOR CALCULUS

BY JAMES D. NICKEL

t	Position Function (distance fallen)	Velocity Function (area under the curve)
5	400	400
6	576	576

Recall that one of the major classes of problems that led to the calculus was the determination of areas and volumes of figures bounded by curves and surfaces. The calculation of areas of figures bounded by straight-line segments (e.g., in our right-angled triangle above, squares, rectangles, parallelograms, etc.) can be performed using the formulas of Euclid's geometry. *It is the area under curved surfaces that proved to be difficult.* The ancient Greeks, particularly Eudoxus (406-355 BC) and Archimedes (287-212 BC), tried various ways to find these areas and anticipated the integral calculus in part. Archimedes estimated the area of the circle by means of calculating the areas 96 circumscribed and 96 inscribed regular polygons. Let's see how in the 17th century, mathematicians Pascal, Fermat, and particularly Leibniz, introduced a general method of approximating curvilinear areas by summing ever smaller and smaller *rectangles*.

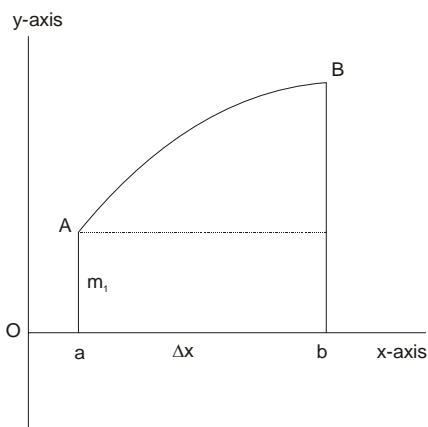

Consider the area bounded by the curve AB, by the vertical lines at $x = a$ and $x = b$ and by the x -axis. We can approximate this area by choosing a *minimum* y -value (m_1 in the figure) and multiplying it by the distance between a and b , namely $b - a$. We will introduce our Δx notation again at this point by letting $\Delta x = b - a$. The area of the rectangle is $m_1 \Delta x$.

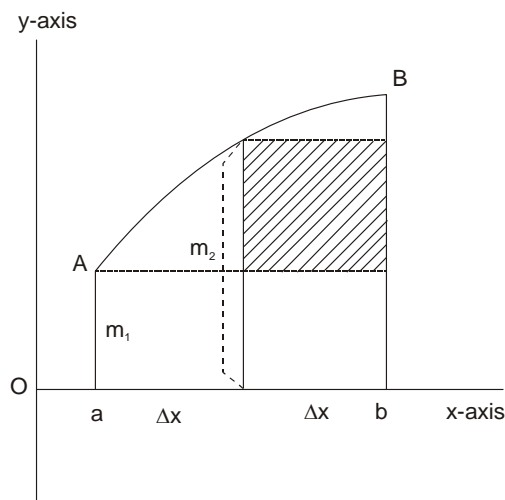

This is our first approximation (or sum) of the area (not very accurate, though). We will denote this sum by $S(\min)_1$. Hence, $S(\min)_1 = m_1 \Delta x$. We can get a better approximation if we divide the interval (a, b) into two equal parts. We will denote the lengths of each of these parts by Δx . If we let m_2 represent the minimum y -value of the second part, we now have a better approximation or sum (we have added the shaded rectangle to the area approximation), denoted as S_2 .

$$S(\min)_2 = m_1 \Delta x + m_2 \Delta x$$

We can continue this procedure *ad infinitum*. We next divide the interval (a, b) into three equal parts and form the sum $S(\min)_3$. Next, we divide the interval into four equal parts and form the sum $S(\min)_4$. In general, we can divide the interval (a, b) into n equal parts and denote the length of each part by Δx . In each part we choose the minimum y -value denoting each as $m_1, m_2, m_3, \dots, m_n$ respectively. We now have the following sum:

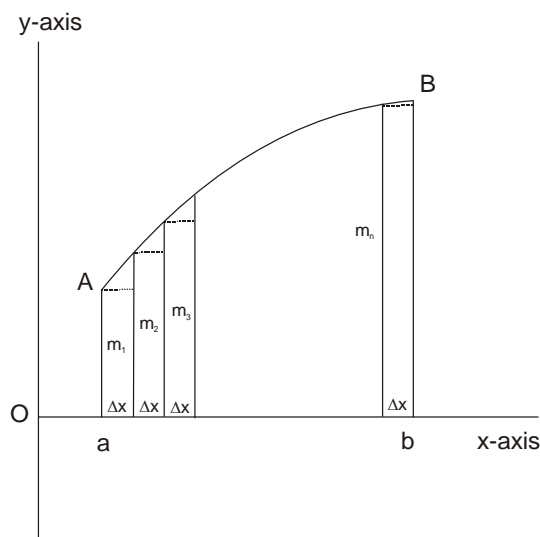

A CASE FOR CALCULUS

BY JAMES D. NICKEL

$$S(\min)_n = m_1\Delta x + m_2\Delta x + \dots + m_n\Delta x$$

Note that as we make n larger (more rectangles to sum), Δx gets smaller and smaller and the closer $S(\min)_n$ approaches the area under the curve. Also, the smaller we make Δx , the less the minimum y -value in any tiny interval Δx differs from other y -values in that same interval of Δx . If we let n increase to infinity, we can state that the sum of these infinitesimally small rectangles, $S(\min)_n$, equals the area, A , under the curve. Using symbols:

$$\lim_{n \rightarrow \infty} S(\min)_n = A$$

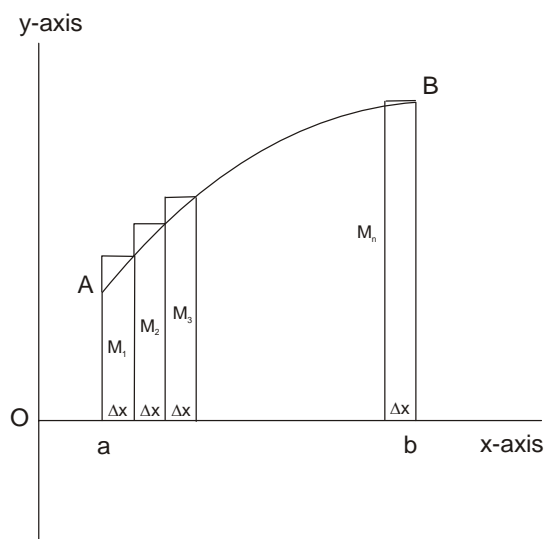

At the limit, we can say the “many *infinitesimally* small sums make a *finite* sum.” The concept of the infinitesimal (with its foundational underpinning of the real number continuum) resolves all of Zeno’s paradoxes of motion *but it took nearly 2,000 years for mathematicians to figure out how to do it!*

Since in these approximations we choose in each Δx the *minimum* y -value (like the inscribed regular polygons of Archimedes), you may be thinking that a little bit of area is being left out. We can obtain another sequence of approximations to the area A if we use the *maximum* y -value (labeled M_1, M_2 , etc.) in each Δx . We are mirroring the circumscribed regular polygons of Archimedes. Note the figure at left.

Using the maximum y -values, we can form this sum:

$$S(\max)_n = M_1\Delta x + M_2\Delta x + \dots + M_n\Delta x$$

Each term in this sum is the area of a rectangle, and each rectangle is larger than that portion of the area under the given curve. But, as n gets larger, Δx gets smaller. In each Δx interval the maximum y -value differs less from the other y -values in that Δx interval. Again, as n approaches infinity, the sum, $S(\max)_n$, approaches the area, A , under the curve:

$$\lim_{n \rightarrow \infty} S(\max)_n = A$$

In essence,

$$\lim_{n \rightarrow \infty} S(\max)_n = \lim_{n \rightarrow \infty} S(\min)_n = A$$

Both methods (minimum y -value and maximum y -value) capture the area under the curve *exactly*.

Before we use the limit concept to formally define the *definite integral* (meaning the “area under a curve”), let’s apply this summation method to our velocity function, $v = 32t$ and see what we get. Let’s try something different. Let’s calculate the area under the curve between $t = 1$ and $t = 5$. Physically, this means we are calculating the distance that the stone travels between $t = 1$ and $t = 5$. Using our position function, $d = 16t^2$, we can calculate this initially as:

$$d(5) - d(1) = 400 - 16 = 384$$

Copyright © 2007

www.biblicalchristianworldview.net

A CASE FOR CALCULUS

BY JAMES D. NICKEL

Note the figure to see how we set up the problem for the summation method.

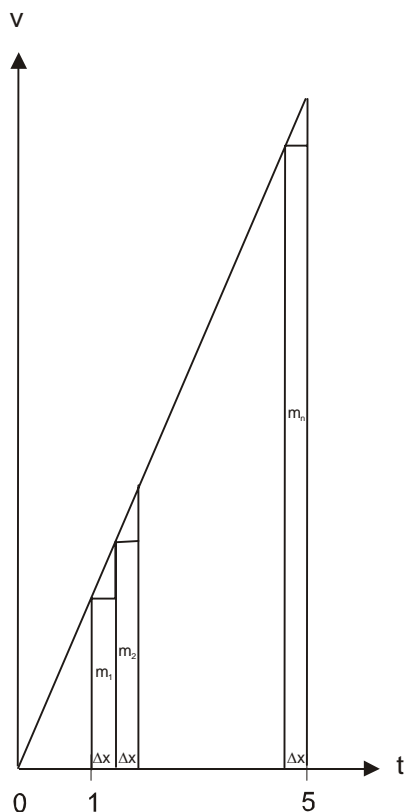

We have divided the interval (1, 5) into n equal parts, each of width Δx . In each Δx interval, we choose the minimum y -value. In the first Δx interval, the minimum y -value, m_1 , is 32 (from $v = 32t$ when $t = 1$). Now, put your algebra hats back on (they've been gathering dust). For the second Δx interval, the minimum y -value, m_2 , is calculated as follows:

$$m_2 = v = 32t = 32(1 + \Delta x)$$

For the third Δx interval, the minimum y -value, m_3 , is calculated as follows:

$$m_3 = v = 32t = 32(1 + 2\Delta x)$$

The same procedure can be applied to each Δx interval. The minimum y -value for the last Δx interval, m_n , can be calculated as follows:

$$m_n = v = 32t = 32[1 + (n-1)\Delta x]$$

The sum, S_n , can be set to the following:

$$S_n = m_1\Delta x + m_2\Delta x + \dots + m_n\Delta x$$

$$S_n = 32\Delta x + 32(1 + \Delta x)\Delta x + 32(1 + 2\Delta x)\Delta x + \dots + 32[1 + (n-1)\Delta x]\Delta x$$

Applying the distributive rule to expand each term, we can restate the sum as follows:

$$S_n = 32\Delta x + 32\Delta x + 32(\Delta x)^2 + 32\Delta x + 32 \cdot 2(\Delta x)^2 + \dots + 32\Delta x + 32(n-1)(\Delta x)^2$$

Copyright © 2007

www.biblicalchristianworldview.net

A CASE FOR CALCULUS

BY JAMES D. NICKEL

Let's rearrange these terms. We first note that the quantity $32\Delta x$ occurs in each term. Because there are n terms, these terms sum to $32n\Delta x$. The remainder of the terms look like:

$$32(\Delta x)^2 + 32 \cdot 2(\Delta x)^2 + \dots + 32(n-1)(\Delta x)^2$$

We can factor a $32(\Delta x)^2$ out of each term. We get:

$$32(\Delta x)^2 [1 + 2 + \dots + (n-1)]$$

Hum, this is interesting, very interesting. Where have we seen $1 + 2 + \dots + (n-1)$ before? This is called the Gaussian sum after Carl Friedrich Gauss's (1777-1855) display of schoolboy genius.³⁹ Recall Mr. Farmer's "counting cows" technique? $1 + 2 + \dots + (n-1)$ is the sum of an arithmetic progression of $n-1$ terms. The formula for this sum, s , is defined as follows:

$$\text{Given } a_1 + a_2 + a_3 + \dots + a_n, \text{ then } s = \frac{(a_1 + a_n)n}{2}$$

In our case, $a_1 = 1$, $a_n = n-1$, and we have $n-1$ terms. Hence:

$$s = \frac{(1+n-1)(n-1)}{2} = \frac{n(n-1)}{2}$$

Now, we can write S_n as follows:

$$S_n = 32n\Delta x + 32(\Delta x)^2 \frac{n(n-1)}{2}$$

We want to find out what happens to this sum as n approaches infinity (and Δx thereby approaches 0). Here is a simple technique to simplify S_n even further. Since we divided the interval (1, 5) into n equal parts, each of width Δx , we know that:

$$\Delta x = \frac{5-1}{n} = \frac{4}{n}$$

Let's substitute this expression for Δx . We get:

$$S_n = 32n\left(\frac{4}{n}\right) + 32\left(\frac{4}{n}\right)^2 \frac{n(n-1)}{2} = 128 + 512 \frac{(n-1)n}{n^2} = 128 + 256 - \frac{256}{n}$$

Make sure you follow the algebra in this last line. As always, follow along with me with a pencil and paper. S_n has now been simplified to the following:

$$S_n = 128 + 256 - \frac{256}{n}$$

To me, the steps taken in simplifying the original expression of S_n is "real neat." In fact, it is more than neat; it is exhilarating, even inspiring! It is another sample of the power of algebra in converting a complex expression into a workable expression. In our simplified expression, it is clear that as n approaches infinity, $\frac{256}{n}$ approaches 0, and S_n approaches $128 + 256 = 384$! In symbols, we get:

³⁹ He determined the sum of $1 + 2 + 3 + \dots + 100$ in seconds.

A CASE FOR CALCULUS

BY JAMES D. NICKEL

$$\lim_{n \rightarrow \infty} S_n = 384$$

I hope you catch the significance of what we've just done. We have shown that the summation process (the calculation of *area* under the curve $v = 32t$ between $t = 1$ and $t = 5$) is *equal* to the *distance* a stone falls between $t = 1$ and $t = 5$ as determined by the position function. Which is easier to calculate? The summation process or making use of the position function? Obviously, it is much easier to use the position function. By our analysis and consequent observations, we have stumbled upon *one of the most efficacious connections in all of mathematics*. This connection is called the *Fundamental Theorem of the Calculus*.

Before we define that theorem, let's formulate the definite integral. Here goes. If $y = f(x)$ is the equation of a curve under which the area lies and we want to find the area between that curve and the x-axis and between two vertical lines at $x = a$ and $x = b$, then A , the area, is defined as follows:

$$A = S_n = m_1\Delta x + m_2\Delta x + \dots + m_n\Delta x$$

Since $m_1 = f(m_1)$, etc, we can rewrite this expression as follows:

$$A = S_n = f(m_1)\Delta x + f(m_2)\Delta x + \dots + f(m_n)\Delta x$$

We can rewrite this as follows:

$$A = \lim_{n \rightarrow \infty} \sum_{i=1}^n f(m_i)\Delta x$$

This is known as the Riemann sum after the German mathematician Georg Friedrich Riemann (1826-1866), the son of a Lutheran pastor.⁴⁰ Leonhard Euler (1707-1783) first used the symbol Σ (capital Greek letter sigma) to represent a summation process. The Riemann sum is just another way of representing S_n . $f(m_i)\Delta x$ (from $i = 1$ to n) represents the respective areas of each of the n rectilinear figures. The sum of all these figures (from $i = 1$ to n as n approaches infinity) equals the area under the curve.

Leibniz introduced the integral sign:



It is a beautiful and elongated S symbolizing summation (in Latin, *summa*). Leibniz denoted the integral calculus as *calculus summatorius*. In Leibniz's honor, mathematicians have symbolized the integral *at the limit* to be:

$$A = \lim_{n \rightarrow \infty} S_n = \lim_{n \rightarrow \infty} \sum_{i=1}^n f(m_i)\Delta x = \int_a^b f(x)dx$$

It is important to note that *at the limit* $f(m_i)$ becomes a point on the curve $f(x)$ and each Δx interval can be represented now by dx (which stands for "a little bit of x"). This is why $f(m_i)\Delta x$ becomes $f(x)dx$. a and b represent the lower and upper bounds of the area curve.

Before we close this section, let's state the Fundamental Theorem of the Calculus. Since it is a theorem, we will not formally prove it. In our discussions above, the proof is contained in the idea that *we can use the position function to calculate the area under a curve*.



Georg Friedrich Riemann (Public Domain)

⁴⁰ Carl Friedrich Gauss was Riemann's mentor.

A CASE FOR CALCULUS

BY JAMES D. NICKEL

Let $f(x)$ be a given function (in our falling stone example, it is the position function) and $f'(x)$ be the derived function or the derivative (in our example, it is the velocity function). The Fundamental Theorem of the Calculus states that:

$$\int_a^b f'(x)dx = f(b) - f(a)$$

This means that to calculate the area under the curve defined by $f'(x)$ between the bounds a and b , all we need to do is to find the anti-derivative of $f'(x)$, namely $f(x)$ and subtract $f(a)$ from $f(b)$. Applying this to our falling stone example, given $f'(t) = 32t$, then $f(t) = 16t^2$. Let $a = 1$ and $b = 5$. Then, the area under the curve $f'(t) = 32t$ between 1 and 5 is calculated as follows:

$$\begin{aligned} \int_1^5 32t dt &= f(b) - f(a) = \\ &16(5^2) - 16(1^2) = \\ &400 - 16 = 384 \end{aligned}$$

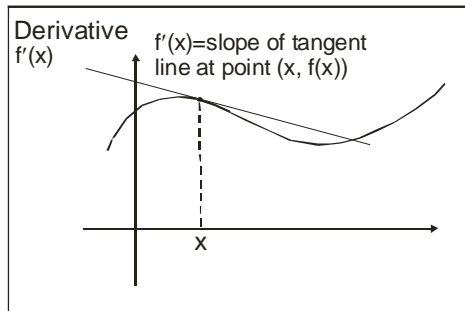

Fundamental Theorem of the Calculus

$$\int_a^b f(x)dx = F(b) - F(a)$$

where F is any antiderivative of f

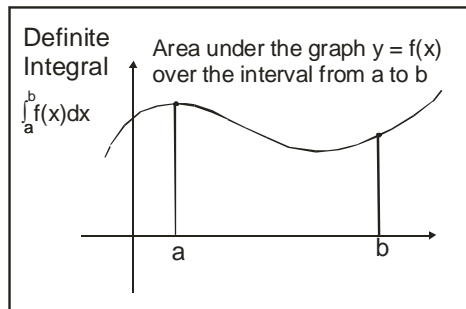

A CASE FOR CALCULUS

BY JAMES D. NICKEL

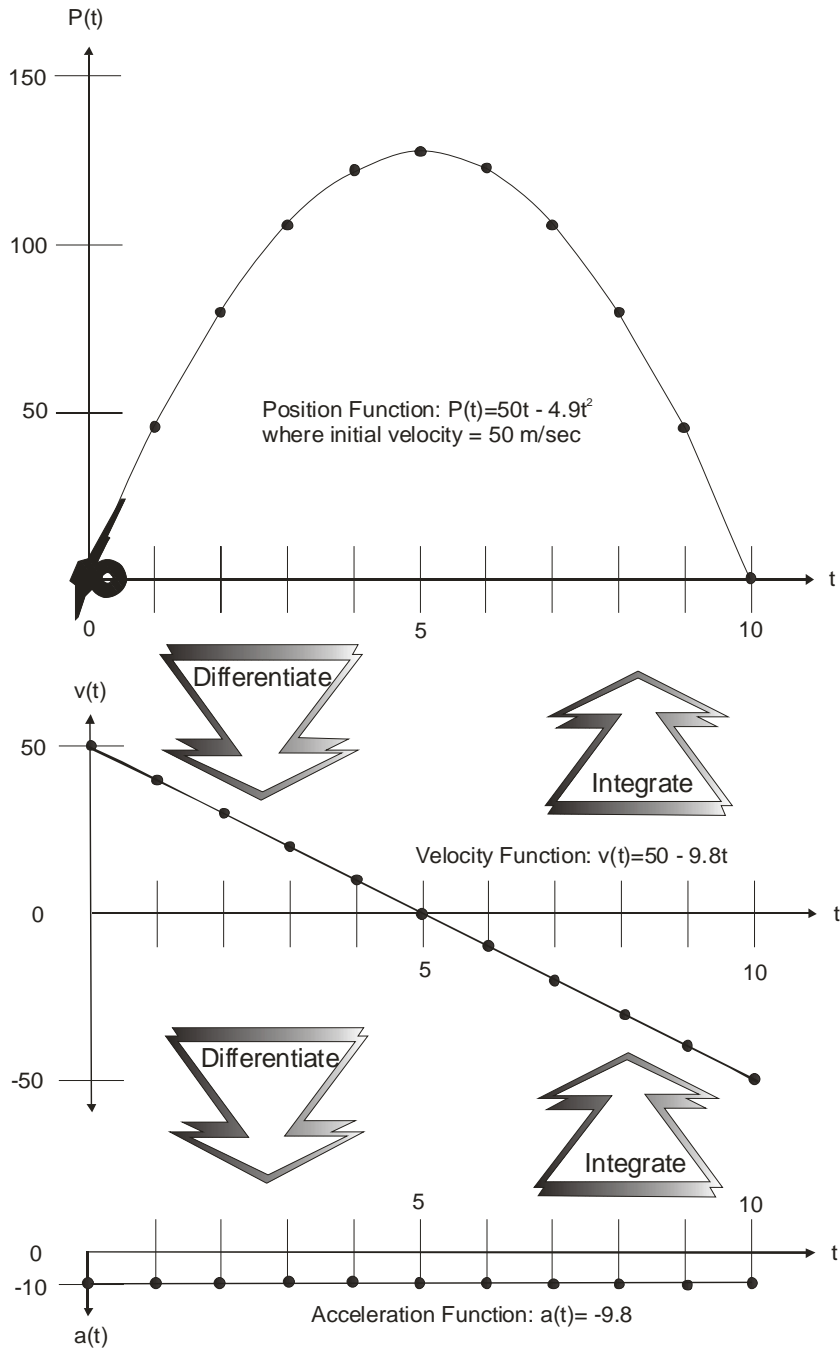

Three mathematical patterns determined by a cannonball: position, velocity, and acceleration. The pattern reflecting the position (what we actually observe in the flight of the cannonball) is a parabola (a somewhat complicated curve). Isaac Newton realized that the pattern reflecting the velocity was a much simpler curve (i.e., a straight line with negative slope) and the pattern reflecting the acceleration was simpler still (i.e., slight line with zero slope). The two basic operations of the calculus, differentiation and integration, give the scientist a tool whereby he can work from one pattern to another. For example, you can start with the simplest pattern, acceleration, and deduce the equation reflecting the position.

A CASE FOR CALCULUS

BY JAMES D. NICKEL

6. PUTTING THE INTEGRAL TO WORK

In this section, we will investigate some elementary examples of how to put the integral calculus to work in solving a variety of problems. Remember that in computing areas bounded by curves we first divide the region into small, regularly shaped regions and then sum the areas of these small sectors. Although each collection of regularly shaped regions is not quite the exact area, *the aggregate measure (at the limit) of all the approximations is the exact area.*

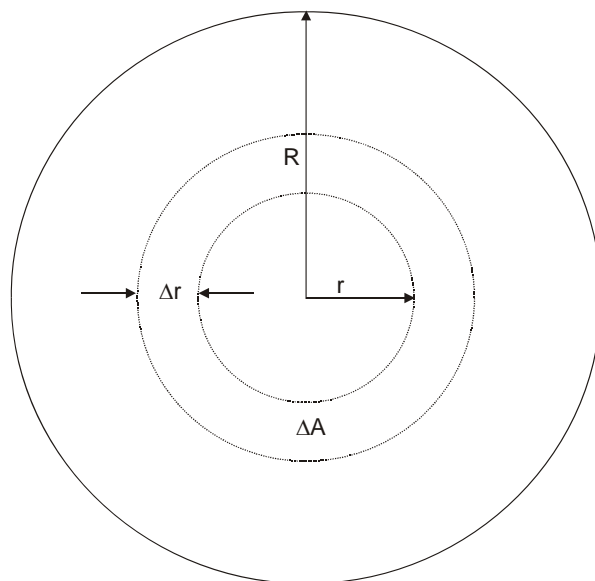

Let's consider a circle. Using the integral calculus, how can we find its area? Consider a tiny ring of width Δr situated at a distance r from the center of the circle. If we consider the entire surface of this ring as consisting of tiny strips, the whole area A of the circle will simply be the summation of these strips. Whenever you sum lots of tiny things, think *integral*. The integral of these strips from $r = 0$ to $r = R$ is the area A of the circle.

We need to develop an expression for the area ΔA of the narrow strip. Think of the strip of width Δr and of a length that is the perimeter (or circumference) of the circle of radius r . This length is $2\pi r$. The area of the strip, ΔA , becomes:

$$\Delta A = 2\pi r \Delta r$$

Hence, the area of the whole circle is the summation of these strips:

$$A = \lim_{n \rightarrow \infty} S_n = \lim_{n \rightarrow \infty} \sum_{i=1}^n 2\pi r_i \Delta r = \int_{r=0}^{r=R} 2\pi r \, dr = 2\pi \int_{r=0}^{r=R} r \, dr$$

Note how we can factor out the coefficient of r , which is 2π . Why? What are we summing?

$$A = 2\pi r_1 \Delta r + 2\pi r_2 \Delta r + 2\pi r_2 \Delta r + \dots + 2\pi r_n \Delta r$$

We can factor out the 2π and get:

$$A = 2\pi (r_1 \Delta r + r_2 \Delta r + r_2 \Delta r + \dots + r_n \Delta r)$$

Given that $f'(r) = r$, then the antiderivative of $f'(r)$ is:

A CASE FOR CALCULUS

BY JAMES D. NICKEL

$$f(r) = \frac{r^2}{2}$$

Applying the Fundamental Theorem of the Calculus, the area of the circle becomes:

$$f(R) - f(0) = \frac{R^2}{2}$$

The area now becomes:

$$A = 2\pi \left(\frac{R^2}{2} \right) = \pi R^2$$

We have calculated the familiar formula for the area of the circle using the technique of integration. Not that hard, was it? It's so simple and elegant that I bet Archimedes is turning over in his grave. Hats off to Newton, Leibniz, and all the rest of those mathematicians who worked on developing and refining the calculus!

Notice in this example that we were not technically calculating the area under a curve. In the integral calculus, as long as we set up a problem with small strips of area to sum and we carefully define the area of those strips, we can confidently apply the methods of the integral calculus.

Let's be brave and venture further, this time into the world of three-dimensions. Let's consider a sphere. What is its volume?

Let's first cut a sphere in half as pictured. We construct a thin spherical shell (similar to a thin dime) of width Δx . The radius of this shell is denoted by y_i . Think carefully what we have done. The thin dime shell standing on its infinitesimally small edge is really a *cylinder*. From Euclidean geometry we can determine the volume of this cylinder. It is the area of the base times the height. The area of the base is the area of the circle of radius y_i . It is πy_i^2 . The height is Δx . The volume of this shell is $\pi y_i^2 \Delta x$.

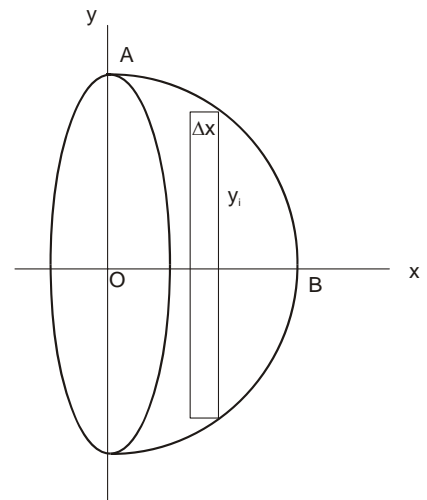

The sum, S_n , of these volumes is approximately equal to half the sphere (or hemisphere). The volume of the sphere will be twice this amount taken to the limit.

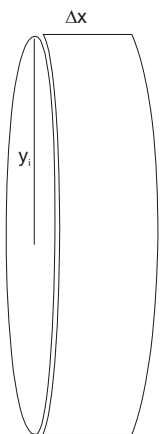

$$V_{\text{sphere}} = 2S_n = 2 \lim_{n \rightarrow \infty} \sum_{i=1}^n \pi y_i^2 \Delta x$$

Given two intervals, $a = 0$ and $b = OB$, this summation at the limit becomes the definite integral:

$$V_{\text{sphere}} = 2 \int_a^b \pi y^2 dx = 2\pi \int_a^b y^2 dx$$

All we need to do now is define the function y^2 in terms of x . We know that the value of y is determined by the equation of the circle with origin at O and radius \overline{OB} (which is also the radius of the sphere). Let $r = \overline{OB}$. We already should know that the equation of a circle with its center at the origin is $x^2 + y^2 = r^2$. Solving for y^2 , we get $y^2 = r^2 - x^2$.

Copyright © 2007

www.biblicalchristianworldview.net

A CASE FOR CALCULUS

BY JAMES D. NICKEL

Our integral now becomes:

$$V_{\text{sphere}} = 2\pi \int_0^r (r^2 - x^2) dx$$

Since $f'(x) = r^2 - x^2$, then the antiderivative of $f'(x)$ is calculated by evaluating each expression. The first expression, r^2 , is merely a constant. Its antiderivative is r^2x . The antiderivative of the second expression, x^2 , is:

$$\frac{x^3}{3}$$

Therefore the antiderivative, $f(x)$, is:

$$f(x) = r^2x - \frac{x^3}{3}$$

Applying the Fundamental Theorem of the Calculus, we get:

$$f(r) - f(0) = r^3 - \frac{r^3}{3} = \frac{3r^3}{3} - \frac{r^3}{3} = \frac{2r^3}{3}$$

Therefore, the volume of the sphere is:

$$V_{\text{sphere}} = 2\pi \left(\frac{2r^3}{3} \right) = \frac{4\pi r^3}{3}$$

Take that to the bank along with a box of cigars. Well done, integral calculus!

Our next example will take us from the confines of areas and volumes to the buildup of water pressure behind a dam. This example is a very important problem that engineers encounter when building such structures. They need to make sure that the dam can withstand the pressure of the water against it. The integral calculus is an indispensable tool for resolving these issues. For simplicity sake, we will let the dam look as follows:

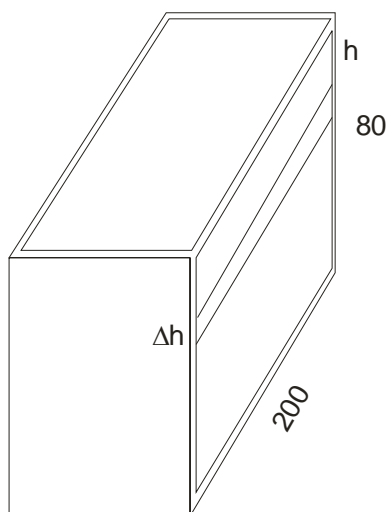

The height of the dam is 80 feet and its width is 200 feet. The surface of the dam that holds back the water is a rectangle of area $80 \times 200 = 16,000$ square feet. Recall from your physics knowledge or, if that is minimal, remember what happens when you dive to the bottom of a swimming pool. As you push deeper and deeper toward the bottom of the pool you feel that your ears are going to pop. In fact, your ears are like an early warning signal telling you that a lot of weight is resting on top of you. You also begin to feel this pressure on the rest of your body; arms and legs do not respond quickly; your muscles are getting tired from the extra effort. The principle of physics that describes this situation is the principle that the pressure of water per square foot varies with depth. Each square foot near the bottom of the pool has more pressure on it than does a square foot near the top of the pool.

Knowing the physics of water pressure, let's return to the dam. We know that water pressure acts equally in all directions. If you do not see this, then poke a hole in the side of a tin can full of water and note the

Copyright © 2007

www.biblicalchristianworldview.net

A CASE FOR CALCULUS

BY JAMES D. NICKEL

water spurting out of the hole; water pressure acts equally in all directions. Since the water pressure varies with depth, we must construct a method whereby we can calculate this pressure at each point on the face of the dam. Consider dividing the face of the dam into narrow strips each of which is Δh in height. Since Δh is “a little bit,” then we can consider that each strip lies roughly at the same depth. To determine the water pressure on each of these strips, we have to calculate the area of each strip. That’s easy; the area is $200\Delta h$. Since water exerts a force of 62.5 pounds per square foot, then, at the depth of b feet, the pressure is 62.5h pounds per square foot. Hence, the pressure on a strip of height Δh that lies at a depth b is $(62.5h)(200\Delta h)$ or the pounds per square foot times the number of square feet.

The total pressure on the face of the dam is found by summing up the pressure for each Δh .

$$T_{\text{pressure}} = S_n = \lim_{n \rightarrow \infty} \sum_{i=1}^n 62.5h(200\Delta h)$$

We want to sum the pressures of these strips from 0 to 80 (the height of the dam; we are starting from the top). Given two intervals 0 and 80, this summation at the limit becomes the definite integral:

$$T_{\text{pressure}} = \int_0^{80} 62.5h(200 dh) = \int_0^{80} 12,500h dh = 12,500 \int_0^{80} h dh$$

Since $f'(h) = h$, then the antiderivative of $f'(h)$ is:

$$f(h) = \frac{h^2}{2}$$

Applying the Fundamental Theorem of the Calculus, we get:

$$f(80) - f(0) = \frac{80^2}{2} - \frac{0^2}{2} = \frac{6,400}{2} = 3,200$$

Therefore, total pressure, in pounds, on the face of the dam is:

$$T_{\text{pressure}} = 12,500 \times 3,200 = 4,000,000$$

If you are a dam builder, then you better withdraw a lot of money from the bank and leave your cigars at home. You are going to need it to buy a lot of concrete and do a lot of work!

Our final example of putting the integral to work will reveal an amazing connection between a branch of mathematics called *probability*⁴¹ theory and the number π (the ratio of the circumference of a circle to its diameter).

Probability theory deals with the study of uncertain events. The origin of the theory can be traced back to France where mathematicians such as Pascal and Fermat tried to quantify games of chance. Consider a die (a cube of six faces). Let the faces contain 1 to 6 dots. Now we throw the die (assumed to be perfectly balanced). In the days of the Old West there is evidence that some of the poker dice were rigged (i.e.; not balanced). Therefore, the gamblers could fix a game for their benefit. You will have to assume that I’m perfectly honest and that my die is balanced. If that is the case, if I roll one die and look at the number of dots on the top face, then the chances of getting any number is $\frac{1}{6}$ or 16.67%.

⁴¹ Probability comes from a Middle English word meaning “plausible.” The Latin word *probabilis* means “to prove.”

A CASE FOR CALCULUS

BY JAMES D. NICKEL

I challenge you to a test. Try throwing a die 1,000 times and count the number of times the number 5 comes up on top. Your answer will be close to 167 with a small margin of error. If you toss the die 1,000,000 times, 5 will come up on top very close to 166,667 times. In general, the probability of an event measures what percentage of the time that event will happen. This percentage does not guarantee that a 5 will come up on your next throw. *Only God knows which number will come up next* (see Proverbs 16:33).⁴² In Old Testament times, “casting of lots” (a lot was a little piece of wood or a pebble) was similar to the throw of a die or a tossing of a coin to see if it will come up “heads or tails.” All the theory of probability says is that as the number of throws approaches infinity, the percentage that 5 will come up on top will approach 16.7% (note the appearance again of limit concept).

Let’s return to 18th century France and peek into the window of house of the French nobleman Georges-Louis Leclerc Comte de Buffon (1707-1788). Here we see a strange event. Buffon, a man of cultural and financial privilege, is tossing breadsticks behind his back onto a tile floor. After each toss, he notes the position of the breadstick on the floor and writes his observation in a notebook. One of his servants removes the breadstick and Buffon throws another one. This “toss the breadstick game” continues for most of the rest of the day. I can only guess that the *noblesse oblige*⁴³ of French aristocracy requires such activity.

Actually, Buffon was a man of great intellect, which he exercised in many fields of endeavor including mathematics and science. In science, he was one of the first men to propose the view that over a number of generations and under the influence of the environment, *one species could gradually change into another* (in direct contrast to the fixity of kind maintained by Genesis 1).⁴⁴ In this context, he was a philosophical precursor to Charles Darwin’s (1809-1892) theory of evolution. In this endeavor, Buffon is an example of a great intellect thinking as a fool philosophically (see Romans 1:22).

Maybe Buffon should have stuck with mathematics, for in this endeavor his breadstick game resulted in an amazing and almost unbelievable discovery. Buffon had his breadsticks “made to order.” Their length was equal to the distance, d , between each tile. His floor looked as follows:

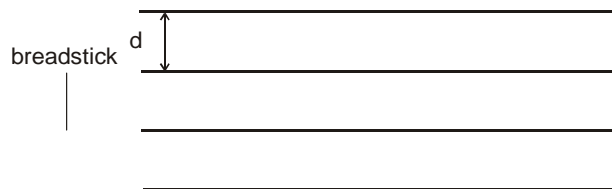

Buffon considered this probabilistic situation. What is the chance that the tossed breadstick will hit a line? As the number of breadstick drops increase, then the measure of the frequency of hits should get closer and closer to the actual probability. Today we have computers that can simulate the throws and do millions of them in seconds. For example, after 1,000,000 throws the computer generates 636,611 hits and, believe it or not, the number π is connected to this result!



Georges-Louis Leclerc Comte de Buffon (Public Domain)

⁴² In this context, the mathematics of probability reminds us that our knowledge is limited; we can never comprehensively know the outcome of some events; only the Biblical God has exhaustive knowledge of *everything* (including the “casting of lots”).

⁴³ *Noblesse oblige* is a French phrase meaning “obligation of nobility.”

⁴⁴ Of course, what the Bible means by “kind” and what evolutionary science means by “species” can differ. The Hebrew for kind means “to portion out” or “a sort.” Groups of living organisms belong in the same created “kind” if they have descended from the same ancestral gene pool. This does not preclude new species because this represents a partitioning of the original gene pool. Information is lost or conserved not gained. A new species could arise when a population is isolated and inbreeding occurs. By this definition a new species is not a new “kind” but a further partitioning of an existing “kind.”

A CASE FOR CALCULUS

BY JAMES D. NICKEL

Before we continue our analysis, let's rewrite Buffon's problem; also called "Buffon's needle." Let a needle (it works just as well as a breadstick and it doesn't break when it hits the floor) of length d be thrown at random onto a horizontal plane ruled with parallel straight lines separated by a distance of d . What is the probability that the needle will intersect one of these lines?

Let's try to describe where the needle could possibly land. We let the length of the needle be 2 units (i.e., $d = 2$). Consider the midpoint of the needle as our reference point. Let's think about its *position* first. Relative to the nearest line, the midpoint could be anywhere from the middle of one side to the middle of the other side. Also, wherever the midpoint lands, the needle could be at any *angle*. Let's measure this angle counterclockwise starting from the horizontal. Position and angle give us everything we need to know as drawn below:

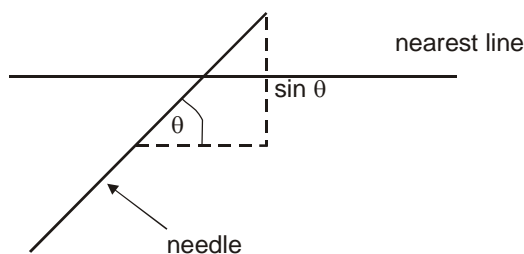

Let's analyze this diagram. First note the right-angled triangle. Since we are considering the midpoint of the needle, the hypotenuse is $\frac{1}{2}$ of 2 or 1. Therefore, $\sin \theta$ measures the length from the midpoint of the needle to the nearest line. If θ is close to 0 (the needle is close to horizontal), then the midpoint must be very close to the line to cause a hit. On the other hand, if θ is close to $\frac{\pi}{2}$ radians or 90° (the needle is close to vertical), then the midpoint can be very far away and still cause a hit. To be specific, if the midpoint's distance from the nearest line is *less than* $\sin \theta$, then the needle will hit the line.

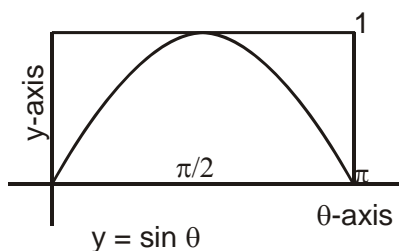

Note that every angle has a set distance where a tossed needle will hit the nearest line. The area of the rectangle above represents all the possible positions of the needle. The needle can be at any angle for 0 to π radians (from vertical to vertical position). The distance that the midpoint of the needle is from the nearest line can range from 0 to 1 (if 0, the center is on one line; if 1, the center is on the adjacent line). The total area of the rectangle is therefore π ($\pi \times 1$). The area under the sine curve between 0 and π represents the probability that the needle will hit the line. The area above the curve represents the probability that the needle will not hit the line. With the integral calculus ready and at hand, let's calculate the area under the curve. We start with the following definite integral:

$$\text{Area} = \int_0^{\pi} \sin \theta \, d\theta$$

Copyright © 2007

www.biblicalchristianworldview.net

A CASE FOR CALCULUS

BY JAMES D. NICKEL

Since $f'(\theta) = \sin \theta$, then the antiderivative of $f'(\theta)$ is $f(\theta) = -\cos \theta$. Applying the Fundamental Theorem of the Calculus, we get:

$$\text{Area} = f(\pi) - f(0) = -\cos(\pi) - [-\cos(0)].$$

Since $\cos(\pi) = -1$ and $\cos(0) = 1$, then:

$$\text{Area} = f(\pi) - f(0) = -(-1) - (-1) = 1 + 1 = 2$$

Aren't you glad you know that to perform arithmetical operations with negative numbers? Since the area under the curve is 2 and the total area is π , then the probability of the needle hitting the line is $\frac{2}{\pi}$.

This probability gives us a method of calculating π (an irrational number) to as many decimal points as we wish. If we know that the probability (at the limit) of the needle hitting the line is $\frac{2}{\pi}$, then after a certain

number of tosses we count that the needle hits the line m times in n tosses, then we would expect that $\frac{m}{n}$

would be about equal to $\frac{2}{\pi}$. We have the following equation:

$$\frac{m}{n} = \frac{2}{\pi}$$

Cross multiplying and solving for π we get:

$$m\pi = 2n$$

$$\pi = \frac{2n}{m}$$

Let's see what our sample of 1,000,000 tosses produces. We got 636,611 hits. Therefore, we can estimate π to be:

$$\pi = \frac{2 \cdot 1,000,000}{636,611} = \frac{2,000,000}{636,611} = 3.141635944$$

The actual value of π to 9 decimal places is 3.141592654.

Hundreds of years after Buffon's "toss the breadstick" game, atomic scientists have discovered that a similar needle-dropping model seems to accurately predict the chances that a neutron produced by the fission of an atomic nucleus would either be stopped or deflected by another nucleus near it. Of course, on the atomic level like on the "lot level," only God could predict this activity accurately. The theory of probability enables scientists to estimate the chances in order to help them better understand and make use of the principles of atomic fission.

In conclusion, we have noted again the connection between seemingly diverse branches of mathematics (probability, integral calculus, and the geometry of the circle) with areas of scientific endeavor (atomic theory). This remarkable and incredible proximate unity and diversity is another example of what we can expect from a universe designed and sustained by the Biblical God, the eternal and ultimate One and the Many. Praise be to His name!

A CASE FOR CALCULUS

BY JAMES D. NICKEL

You are worthy, O Lord, to receive glory and honor and power; for You created all things (needles, breadsticks, the mind of man, atomic structure), and by Your will they exist and were created (Revelation 4:11).

A CASE FOR CALCULUS

BY JAMES D. NICKEL

7. SYNOPSIS

Our short journey into the land of the calculus has come to an end. This does not mean that we have traveled to every corner of this realm. Much remains to be investigated and discovered. I have just led you on a whirlwind tour of some of the principal locations; enough, I hope, to whet your appetite for more adventures. Maybe, in God's providence, I will be able to escort you on subsequent excursions to other mathematical lands.

I want you now to take stock of starting points and ending points. The ability to count is due to the nature of God *imaged in man*. Hence, mathematics begins with the revelation of the infinite and eternal God and His Word. To be wise, we must respect or give heed to His authoritative revelation (i.e., the Bible) if we want to know anything aright. We call this the epistemological foundation for understanding and doing mathematics.

Next, note that God's being, His Triune nature (the ultimate "one and the many") forms the ultimate reality basis for a true understanding of the created reality (the proximate "one and the many"). We call this the metaphysical foundation for understanding and doing mathematics.

From this epistemological and metaphysical foundation, we start with the counting numbers: 1, 2, 3, 4, ... and note how this set continues without end or *ad infinitum*. Then we build upon these numbers (i.e., zero, integers, rational numbers) until we reach the "height" of the real number continuum. Above, in the clouds, we also note the appearance of the imaginary unit; a strange and mysterious abstraction that found its way into many intriguing and astonishing scientific and mathematical locales. As the floors of this superstructure ascend, we can enter into many rooms containing a wide variety of beautiful and wondrous mathematical furnishings. All along the pathway, *infinity* seemed to be a constant and somewhat "mind-boggling" companion.

The spirit of genuine mathematics, i.e., its methods, concepts, and structure – in contrast with mindless calculations – constitutes one of the finest expressions of the human spirit. The great areas of mathematics – algebra, number theory, combinatorics, real and complex analysis, topology, geometry, trigonometry, etc. – have arisen from man's experience of the world that the infinite, personal, Triune, and Sovereign God has created and currently sustains. These branches of mathematics, constructively developed by man made in the image of God, enable man to systematize the given order and coherence (the unity in diversity ... the proximate one and the many) of creation mediated to us by the Creator and upholder of all things – the logos and wisdom of God revealed in the person of the Lord Jesus Christ. This systematization not only gives man a tool whereby he can take effective dominion over the creation under God in Christ, but also gives man the experience and enjoyment of a rich intellectual beauty that borders the sublime in its infinitely complex, yet structured mosaic.

Who, by a vigor of mind almost divine,
the motions and figures of the planets,
the paths of comets, and the tides of the
seas first demonstrated.

Newton's epitaph

A CASE FOR CALCULUS

BY JAMES D. NICKEL

Near the apex of our building we see, based upon this rudimentary introduction to the calculus, that the *limit* subdues *infinity*. Originally discovered in the 17th century (with its philosophical underpinnings secured by Biblical theology), mathematicians since then have been exploring the implications of the calculus. A few basic abstract principles (the real number continuum, the continuous function concept, coordinate geometry, the limit concept, instantaneous velocity, and area under a curve) have generated a plethora of scientific and technical applications (from airplane construction to rockets shot to the moon and back). The success of the calculus, in the words of David Berlinski, “is among the miracles of mankind.”⁴⁵ In spite of these marvelous applications, most mathematicians consider the calculus to be *just the beginning*. In the 20th century mathematicians have journeyed into realms in which the methods of the calculus play little or no part; e.g., the patterns revealed by fractal geometry. Who knows

... from motion's simple laws
Could trace the secret hand of Providence
wide-working through this universal frame.

James Thomson, in his *Memorial Poem to Isaac Newton*

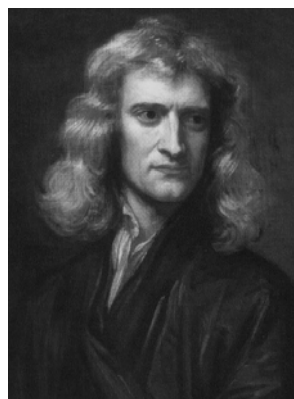

Isaac Newton (Public Domain)

what the 21st century and beyond hold for mathematics? In this context, we should take the words of Isaac Newton to heart. God gifted Newton, a man who studied theology as much as he studied mathematics, with an extraordinary and perhaps unexcelled ability to see a physical problem and treat it mathematically. He said:

I do not know what I may appear to the world; but to myself I seem to have been only like a boy playing on the seashore, and diverting myself in now and then finding a smoother pebble or a prettier shell than ordinary, whilst the great ocean of truth lay all undiscovered before me.⁴⁶

We have not yet exhausted the “great ocean of truth” planted in the created realm by the Creator. I personally think we never will exhaust this ocean. What part will you, my reader, play in this exploration of discovery (if not in mathematics, then in some other created realm)? Let me

remind you of a few basic principles of discovery as illustrated by the life of the agricultural chemist of international fame, George Washington Carver (1864-1943). In a speech made to the YMCA of Blue Ridge, North Carolina in 1920, Carver explained how he discovered the secrets and the multitudinous uses of the peanut:

Years ago I went into my laboratory and said, “Dear Mr. Creator, please tell me what the universe was made for?”

The Great Creator answered, “You want to know too much for that little mind of yours. Ask for something more your size, little man.”

Then I asked. “Please, Mr. Creator, tell me what man was made for?”

Again the Great Creator replied, “You are still asking too much. Cut down on the extent and improve the intent.”

So then I asked, “Please, Mr. Creator, will you tell me why the peanut was made?”

“That’s better, but even then it’s infinite. What do you want to know about the peanut?”

“Mr. Creator, can I make milk out of the peanut?”



George Washington Carver (Public Domain)

⁴⁵ Berlinski, p. xiii.

⁴⁶ Cited in Howard Eves, *An Introduction to Mathematics* (New York: Holt, Rinehart, and Winston, [1953, 1964, 1969] 1976, pp. 326-327.

A CASE FOR CALCULUS

BY JAMES D. NICKEL

“What kind of milk do you want? Good Jersey milk or just plain boarding house milk?”

“Good Jersey milk.”

And then the Great Creator taught me to take the peanut apart and put it together again. And out of the process have come for all these products!⁴⁷

What was the secret of Carver’s success? Let him say it in his own words:

The secret of my success? It is simple. It is founded in the Bible, “In all thy ways acknowledge Him and He shall direct thy paths.”⁴⁸

God will blessedly direct the path of mathematics only to the extent that the mathematical community acknowledges God in all their epistemological and metaphysical ways. Under the protection of the umbrella of the Biblical worldview, I now want to define mathematics:

Mathematics is a mental discipline that makes use of the *abstract* formulation of ideas suggested by the patterned structure of God’s creation (the *concrete*). It is the artful use of the God-given reasoning processes to make connections (find unity in diversity) and then to infer and deduce new facts about creation; i.e., to discover the wisdom of God in Christ hidden in creation (see Proverbs 25:2). It is a series of significant assertions about the nature of creation and its conclusions impact almost all the arts and sciences (either in the context of aesthetical beauty or dominion mandate applications).

As a final synopsis, I want to analyze how the Biblical worldview specifically speaks to and makes sense of the methods of the calculus.

The real number continuum is the fundamental numerical basis for understanding not only the calculus, but also any quantitative analysis of God’s created order. It is upon the real number continuum that the function concept rests. A function is described in mathematical symbols by a formula in terms of dependent (range) and independent (domain) variables. We can get a geometric “feel” for a formula by graphing it on the Cartesian coordinate plane. This grid, consisting two axes reflecting the real number continuum (the x-axis the real number domain and the y-axis the real number range), unites form (shape) and number (generalized arithmetic in the guise of symbolic algebra). This proximate union of form and number reflects on the way the infinite, triune God (the ultimate One and the Many) has structured both the physical creation and man’s intellectual capacities. Man’s mind, by creative design, is geared toward unifying diverse aspects of the created reality; i.e., to find the general or unifying principle from the specific or particular. The Cartesian coordinate system, in which form and number are united, is one of many examples of this “unity in diversity” principle. It is in the particular world of God’s creation (mind and matter, the invisible and the visible) that mathematics is not so much applied as *revealed*.

It was through the study of motion that the differential calculus found its first illustration. Given a position function (change of distance in terms of time), the first derivative generates a velocity function (change of speed in terms of time). Then it was discovered that velocity *is an aspect of curvature*. The graph of a position function makes “visible” instantaneous velocity (the slope of the tangent line at any point on the curve). It is the derivative that unifies two diverse aspects: velocity and curvature.

⁴⁷ Cited in Ethel Edwards, *Carver of Tuskegee* (Cincinnati: Ethel Edwards & James T. Hardwick, 1971), pp. 114-117. Carver discovered nearly 300 derivative products from his investigation of the peanut.

⁴⁸ George Washington Carver, *Bless Your Heart* (Eden Prairie, Minnesota: Heartland Samplers, Inc., 1990), 7.12.

A CASE FOR CALCULUS

BY JAMES D. NICKEL

After investigating this revelation, mathematicians then considered the position function as a *general* concept. Instead of viewing it as change in distance in terms of time, they viewed it as a change in any dependent variable in terms of an independent variable (coordinated by the function concept). From this generalization concept came a plenitude of further illustrations.

Here again, in the differential calculus, is “unity in diversity” principle revealed. First, in the derivative that unifies velocity and curvature. Second, one principle, a generalized “position” function, now located in a diversity of characterizations.



Weierstrass

Karl Weierstrass (Public Domain)

Instantaneous velocity is defined as the derivative of a function and area as the integral of a function.

We have seen how both the derivative and the integral make use of the limit concept, which was finally given a rigorous definition by the German mathematician Karl Weierstrass (1815-

1897) in 1854. In making possible the definition of the derivative, the limit concept unifies two diverse aspects of experience; the *discrete* and the *continuous*. Discrete, Latin for separate, refers to a situation where possibilities are distinct and separate from each other. For example, the

The whole of mathematical history may be interpreted as a battle for supremacy between these two concepts (the discrete and the continuous – JN). This conflict may be but an echo of the older strife so prominent in early Greek philosophy, the struggle of the One to subdue the Many. But the image of a battle is not wholly appropriate, in mathematics at least, as the continuous and the discrete have frequently helped one another to progress.

Eric Temple Bell, *The Development of Mathematics*, p. 13.

The *integral* or the area A under the curve denoted by the function $f(x)$ (say “ f of x ”) between the lower bound a and the upper bound b is formally defined as:

$$A = \lim_{n \rightarrow \infty} \sum_{i=1}^n f(m_i) \Delta x = \int_a^b f(x) dx$$

lim stands for “limit.” Σ means “summation or aggregate.” Δx (read “delta x ”) means “infinitesimally small difference in x .” $f(m_i) \Delta x$ represents the area (length times width) of an infinitesimally small rectangle. We are finding the aggregate of an infinite number of such rectangles. At the limit, $f(m_i)$ becomes a point on the curve $f(x)$ and each Δx interval can be represented now by dx (which stands for “a small change in x ”). This is why $f(m_i) \Delta x$ becomes $f(x) dx$.

The *derivative* of the function $f(x)$ is written $f'(x)$ and is formally defined as:

$$\lim_{\Delta x \rightarrow 0} \frac{f(x + \Delta x) - f(x)}{\Delta x}$$

This procedure effectively calculates a specific number; i.e., the slope (the ratio of rise to run) of the line tangent to the curve represented by $f(x)$ at any point x .

number of people in a town is discrete; you cannot have a fraction of a person. Measurements of time and distance, as we have noted, are not discrete because they can vary over a continuous range. The position function reflects a *continuous* process (the position of a moving object over time). The limit of a function is a limit of an infinite series taken to *infinity*. The limit is *discrete*; it is a distinct number (whether as the convergence to a specific number in the derivative or the

Copyright © 2007

www.biblicalchristianworldview.net

A CASE FOR CALCULUS

BY JAMES D. NICKEL

aggregate area in the integral). The limit of a function is the convergence of infinitely many numbers. The limit illustrates the instantaneous (or *continuous*) way in which an object is changing its position. The concept of limit, a concept that defied comprehensive definition until 1854 (*over 2,000 years after Zeno's brain-teasers first cried out for its definition*), is another revelation of the “unity and diversity” principle.

Like addition to subtraction, multiplication to division, and raising a power to extraction of roots, differentiation is the inverse operation of integration. The derivative and integral are two sides of the same coin. In the words of Larry L. Zimmerman:

“... they developed for some time along parallel paths. They seemed to be completely different ideas. The big surprise (to those who thought them separate works of art) came when it was observed that they were actually inverses of each other. Though appearing to bounce around in history at the whim of its “creators,” mathematics truly hangs together.⁴⁹

Both differentiation and integration characterize diverse realms (instantaneous velocity and area under a curve). In this context, both are independent of each other.

Although independent of each other, they are connected in their dependence upon the limit concept.

The position function gives us a “sense” of place. The velocity function (the derivative of the position function) gives us a “sense” of differences of position. On the Cartesian coordinate grid, this “sense” is pictured as curvature (the slope of the tangent to the point on the curve). Amazingly, the definite integral calculates the area under this curve from position *a* to position *b*! This area is the distance traveled from position *a* to position *b*. *Distance and area are one number.* This connection should stun and awe the beholder because distance is essentially a one-dimensional concept. Area is a two-dimensional concept. That both should be the same in the calculus is almost too stupefying to consider!

Note the conceptual coherence. The derivative of position is velocity (the measure of how fast an object has gone by). The indefinite integral of velocity is distance, the measure of how far an object has been going that fast! It is the Fundamental Theorem of the Calculus (afterwards denoted as FTC) that unveils this remarkable and astounding coherence (unity in diversity) that might otherwise go unnoticed.

The Fundamental Theorem of the Calculus

This connection was first noted by Isaac Barrow (1630-1677), Newton's mentor. Augustin-Louis Cauchy (1789-1857) presented the first rigorous demonstration of the theorem. Let $f(x)$ be a given function (in our falling stone example, it is the position function) and $f'(x)$ be the derived function or the derivative (in our example, it is the velocity function). The Fundamental Theorem of the Calculus states that:

$$\int_a^b f'(x)dx = f(b) - f(a)$$

This means that to calculate the area under the curve defined by $f'(x)$ between the bounds a and b , all we need to do is to find the anti-derivative of $f'(x)$, namely $f(x)$ and subtract $f(a)$ from $f(b)$. Applying this to our falling stone example, given $v = f'(t) = 32t$, then $s = f(t) = 16t^2$. Let $a = 1$ and $b = 5$. Then, the area under the curve $f'(t) = 32t$ between 1 and 5 is calculated as follows:

$$\int_1^5 32tdt = f(b) - f(a) = \\ 16(5^2) - 16(1^2) = 400 - 16 = 384$$

⁴⁹ Zimmerman, p. 9.

A CASE FOR CALCULUS

BY JAMES D. NICKEL

Note the range of influence revealed by the FTC. It proceeds from the particular to the global (or universal), from diversity to unity, from the many to the one. The derivative of a function converges to a discrete single number, a local particularity. The integral of a function aggregates to a continuous region in space, a global (or unified) vista. According to the FTC, if we are given a continuous global function, then we can apply anti-differentiation and recover the local particular function. Reversing the procedure, given a local, continuous function, we can differentiate it and determine the global function. From the derivative to the integral and from the integral to the derivative, from the many (the particular) to the one (global) and from the one (global) to the many (the particular), is the way revealed by the FTC.

This interplay between the one and the many is a fundamental metaphysical conundrum that, in the history of the philosophy of mathematics (in fact, in the history of philosophy), finds no satisfactory resolution. The solution to this interplay finds its true accord *only in the Biblical worldview*. In the triune Godhead, both the one and the many are equally ultimate. In the unity of the Godhead,⁵⁰ there are three persons, coeternal and coequal, all three fully God, but each distinct in existence. The three distinct persons (or particulars) are the Father, the Son, and the Holy Spirit. All the “particulars” of the Godhead are related to the “universal” and the “universal” is fully expressed in the “particulars.” The Father is fully God, the Son is fully God, and the Holy Spirit is fully God. In this sense we can say that the many and the one of the Godhead are both *equally ultimate*. When the triune God creates, He externalizes His very nature in what He makes (both invisible and visible realms). Creation is a temporal or proximate revelation of the eternal “One and the Many.” The FTC reveals a proximate and equally ultimate interplay between the “one and the many” of the derivative and the integral.

It is the glory of God to conceal a matter, but the glory of kings is to search out a matter (Proverbs 25:2).

The deepest purposes of the fundamental connections in mathematics (the proximate one and the many) of which the FTC is one example does not reveal or generate the patterned order or laws of the created reality. These connections serve the purpose of allowing these patterns (which are faint echoes of God’s covenantal faithfulness in His sustaining power) *to be revealed*.

I would like to explore one more connection revealed by the calculus before I say good-bye. As we have noted, the derivative historically began with the analysis of a *concrete* or physical situation; e.g., a falling stone.

Beginning with the concrete (the position function), differentiation ends with an *abstract* mathematical object. This object is the derivative of the position function (the velocity function), a real number function from which we can calculate a quantity called instantaneous velocity. Contrariwise, integration begins with an *abstract* mathematical object (the area under a curve) and ends with a *concrete* revelation (the distance traveled by a falling stone).

This balanced “give and take” between the abstract and the concrete reflects upon the nature of the calculus (and the nature of mathematics in general) at the deepest level. From the patterned structures of God’s created reality, we can use our minds, created in His image, to formulate abstract ideas. By the methods and tools that the structure mathematics furnishes us, we can discover the wisdom of God in Christ hidden in the creation. We can then use our conclusions to either increase (1) our appreciation of the beauty of mathematics in its

All Biblical Christian intellectual activity, in whatever field it takes place, is an attempt to discover and understand the interconnectedness of the created order, both visible and invisible.

⁵⁰Deuteronomy 6:4 states that “God is one.” The Hebrew word translated as “one” is transliterated *echad*. This word does not refer to mathematical singularity (as the Hebrew word transliterated *yachid* does); it denotes a compound or collective unity (i.e., a unity of persons).

A CASE FOR CALCULUS

BY JAMES D. NICKEL

reflection of the created realm or (2) the beneficial impact of mathematics upon culture via improved technology (i.e., dominion mandate applications).

I leave you now. Thank you for the companionship. I hope that this end is a beginning for you. One of the great features about mathematics is that, in the words of Newton, a “great ocean of truth” still lies ahead of us. As Carver discovered with the peanut, there is a treasure house in the creation waiting for us to discover its precious nuggets. It is up to you to follow their example in the vocation that God calls you to. I pray that you will discover that call. If the call is not to mathematics or science (not everyone is called to this arena of God’s kingdom), I hope that you have learned some universal and pertinent truths that can be applied to any vocation. I hope that you have learned that patience and perseverance in study pays off with a rich reward of pleasurable understanding. I hope that you have seen that mathematics is the artful use of the God-given reasoning process to find “unity in diversity” in the created realm. I hope that you have, along with me, been able to penetrate and discover some of the hidden wisdom of God’s creation in Christ revealed through mathematics and science. As you and I have detected some of these wondrous and remarkable connections, I hope that you have glorified and worshipped the One in whom these connections cohere. I certainly have.

*The works of the Lord are great,
Studied by all who have pleasure in them.*
Psalm 111:2